

Bid No. 610-006

Temporary Clay Tile Roof Repair

For

**Science & Applied Studies Building
Germantown Campus**

**Montgomery College
Maryland**

**Date: October 28, 2009
Montgomery College
Office of the Central Facilities
40 W. Gude Drive
Suite 200
Rockville, MD 20850**

This Page is Intentionally Left Blank

MONTGOMERY COLLEGE
SCIENCE & APPLIED STUDIES BUILDING
TEMPORARY CLAY TILE ROOF REPAIR
GERMANTOWN CAMPUS

TABLE OF CONTENTS

INTRODUCTORY INFORMATION

00001	Cover Page
00010	Table of Contents
00015	List of Drawings

BIDDING REQUIREMENTS

00101	Request for Bid
00200	Instructions for Bidders
00210	Supplementary Bid Information and Conditions
00211	Required Submissions
00410	Bid Form
00431	Bid Bond
00453	Minority Participation Form
00454	Procurement Office Questionnaire

CONTRACTING REQUIREMENTS

00611	Montgomery College Standard Performance Bond
00612	Payment Bond
00621	Application and Certificate for Payment
00700	Montgomery Community College General Conditions

APPENDIX A

Travel Directions to Pre-Bid Conference Site

TECHNICAL SPECIFICATION SECTIONS & DRAWINGS

END OF TABLE OF CONTENTS

This Page is Intentionally Left Blank

**MONTGOMERY COLLEGE
SCIENCE & APPLIED STUDIES BUILDING
TEMPORARY CLAY TILE ROOF REPAIR
GERMANTOWN CAMPUS**

LIST OF DRAWINGS

RP-1	Roof Plan
1	Detail 1
2	Detail 2
3	Detail 3
4	Detail4

END OF LIST OF DRAWINGS

This Page is Intentionally Left Blank



Procurement Office, Administrative Center
900 Hungerford Drive, Room 110
Rockville, Maryland 20850
Phone: (240) 567-5292

REQUEST FOR BID

No. **610-006**

DATE ENTERED	BID CLASS	PAGE	of
--------------	-----------	------	----

THIS IS NOT AN ORDER

**MONTGOMERY COLLEGE
GERMANTOWN CAMPUS**

**SCIENCE & APPLIED STUDIES BUILDING
TEMPORARY CLAY TILE ROOF REPAIR**

BID NUMBER 610-006

Bids are being solicited for the Temporary Clay Tile Roof Repair for Science & Applied Studies Building on Germantown Campus. Bids must either be mailed or hand delivered to the Procurement Office (Room 110) of Montgomery College at 900 Hungerford Dr., Rockville, Maryland 20850 on or before the date and time defined below. Proposals cannot be accepted over facsimile lines. Bids will not be accepted if received after the opening time and date specified or if sent by facsimile. Bids will be opened publicly at the date and time indicated below. Contractors do not need to be present at the bid opening.

THIS BID WILL BE ACCEPTED UNTIL THE CLOSING TIME OF 3:00 PM LOCAL TIME ON November 12, 2009.

Bidder who would like to have a copy of the bid tabulation sheet are to include a stamped, self-addressed envelope with their bid.

Bid offer must remain valid for **ninety (90) calendar days**. Prices must remain firm for the duration of the term of the contract. All required submissions must accompany each proposal.

A Pre-Bid Conference will be held on **November 3, 2009 at 2:00 p.m. in Room 105, Goldenrod Building, 20271 Goldenrod Lane, Germantown, MD 20876-4064**. Site inspection will be conducted after the conclusion of the Pre-bid Conference. Attendance by all bidders is strongly encouraged.

The bid documents may be obtained at Montgomery College's Office of Central Facilities, 40 West Gude Drive, Suite 200, Rockville, MD 20850 on or after October 28, 2009. Contractors are advised that each set of bid documents (drawings and specifications), will cost \$10, plus any applicable delivery charges. An electronic bid document in PDF format may be obtained by downloading the file from the procurement website <http://www.montgomerycollege.edu/departments/procure/> at no charge.

All procurement questions shall be directed to Yu Zhu (Judy), Procurement Supervisor, Construction, Montgomery College, Phone: 240-567-5284, Fax: 240-567-6397, E-mail: yu.zhu@montgomerycollege.edu.

All technical questions shall be directed, in writing, no later than **5:00 PM, November 9, 2009**, to Eric Koh, AIA, **College Architect, Phone: 240-567-7364, Fax: 240-567-7379, E-mail: eric.koh@montgomerycollege.edu**. Only answers provided via an addendum issued by the College will be binding.

BID AND PERFORMANCE SECURITY REQUIREMENTS: 10% Bid Bond & 100% Performance, Labor and Materials Bond.

MINORITY VENDORS ARE ENCOURAGED TO RESPOND TO THIS SOLICITATION.

NO ALLOWANCES SHALL BE MADE TO THE SUCCESSFUL BIDDER, AT A LATER DATE, FOR ADDITIONAL WORK REQUIRED BECAUSE OF HIS/HER FAILURE TO INSPECT THE PROJECT SITE.

IMPORTANT: YOUR BID WILL BE JEOPARDIZED IF ANY PORTION OF THIS INQUIRY IS NOT COMPLETE. NO BID/PROPOSAL WILL BE ACCEPTED AFTER THE DATE AND TIME STATED ABOVE.

Janet Wormack
Director of Procurement

CONDITIONS AND INSTRUCTIONS

1. **ADDITIONAL ORDERS:** Unless it is specifically stated to the contrary in the bid response, the College reserves the option to place additional orders against a contract awarded as a result of this solicitation at the same terms and conditions, if it is mutually agreeable.
2. **APPLICABLE LAW:** This contract shall be construed and interpreted according to Maryland law.
3. **ASSURANCE OF NON-CONVICTION OF BRIBERY:** The bidder hereby declares and affirms that, to its best knowledge, none of its officers, directors or partners and none of its employees directly involved in obtaining contracts has been convicted of bribery, attempted bribery or conspiracy to bribe under the laws of any state or the Federal government.
4. **AUDIT:** Bidder shall permit audit and fiscal and programmatic monitoring of the work performed under any contract issued from this solicitation. The College shall have access to and the right to examine and/or audit any records, books, documents and papers of bidder and any subcontractor involving transactions related to this Agreement during the term of this Agreement and for a period of three (3) years after final payment under this Agreement.
5. **AWARD CONSIDERATIONS:** Awards of this bid will be made to the lowest responsible bidder conforming to specifications with consideration being given to quantities involved, time required for delivery, purpose for which required, responsibility of bidder and its ability to perform satisfactorily with consideration to any previous performance for Montgomery Community College. A bid may be awarded at the sole discretion of the College in the best interest of the College. Prompt payment discounts will not be considered in bid evaluation. All discounts other than prompt payment are to be included in bid price.
6. **BID AND PERFORMANCE SECURITY:** If bid security is required, a bid bond or cashier's check in the amount indicated on the bid cover must accompany each bid and be made payable to Montgomery Community College. Corporate or certified checks are not acceptable. Bonds must be in a form satisfactory to the College and underwritten by a company licensed to issue bonds in the State of Maryland. If bid security fails to accompany the bid, it shall be deemed unresponsive, unless the Director of Procurement deems the failure to be nonsubstantial. Such bid bonds or checks will be returned to all except the three (3) lowest bidders within five (5) days after the opening of bids, and the remaining checks or bid bonds will be returned to all but successful bidder(s) within forty-eight (48) hours after award of contract. If a performance bond is required, the successful bidder must submit an acceptable performance bond in the designated amount of the bid award, prior to award of contract. All bid bonds will be returned to the successful bidder(s) within fortyeight (48) hours after receipt of the performance bond.
7. **BRAND NAMES:** Brand name materials used in these specifications are known and acceptable. Bids including proposals to use alternate brands are invited as long as they are of equal type and equal or better quality. The burden of proof that alternate brands are in fact equal or better falls on the bidder, and proof must be to the College's satisfaction.
8. **COMPLIANCE WITH LAWS:** Bidder agrees to comply, at no additional expense, with all applicable Executive orders, Federal, State, bi-county, regional and local laws, ordinances, rules and regulations in effect as of the date of this Agreement and as they may be amended from time to time, including but not limited to the equal employment opportunity clause set forth in 41 CFR 60-250.4.
9. **CONTINGENT FEES:** Bidder hereby declares and affirms that neither it nor any of its representatives has employed or retained any person, partnership, corporation, or other entity, other than a bona fide employee or agent working for the bidder, to solicit or secure a contract, and that it has not paid or agreed to pay any person, partnership, corporation, or other entity, other than a bona fide employee or agent, any fee or any other consideration contingent on the making of a contract as a result of this solicitation.
10. **DELIVERY AND PACKING:** All prices quoted must include delivery. All goods delivered under this contract shall be packed in accordance with accepted trade practices. No charges may be made over and above the bid price for packaging, or for deposits or containers unless specified in the bid. No charge will be allowed for cartage unless by prior written agreement. Complete deliveries must be made by the successful bidder to the designated location as indicated on the Montgomery Community College purchase order. A packing slip shall be included in each shipment. All deliveries must be prepaid and must be delivered to each location designated on purchase order at no additional cost. **DELIVERIES MUST BE MADE TO THE SPECIFIED LOCATION. NO COLLECT SHIPMENTS OR SIDEWALK DELIVERIES WILL BE ACCEPTED.**
11. **DELIVERY OF BIDS:** Sealed bids must be received in the Procurement Office by the date and time specified in the bid in order to be considered. **NO LATE BIDS OR PROPOSALS WILL BE ACCEPTED.** Late bids will be returned to the bidder unopened. Bids submitted by mail must be addressed to the Procurement Office, Montgomery College, P.O. Box 1006, Rockville, Maryland 20850, and clearly marked to indicate the bid number, title and opening date. Hand delivered bids will be accepted only at the Procurement Office, Montgomery College Central Administrative Center, Room 110, 900 Hungerford Drive, Rockville, Maryland 20850.
12. **DISPUTES:** Any dispute arising under a contract awarded as a result of this bid which is not disposed of by agreement shall be decided by the President of the College or designee. Pending the final decision of the dispute, contractor shall proceed with the contract performance. Nothing hereunder shall be interpreted to preclude the parties from seeking after completion of the contract any and all remedies provided by law.
13. **ERRORS IN BIDS:** Bidders are assumed to be informed regarding conditions, requirements, and specifications prior to submitting bids. Failure to do so will be at the bidder's risk. Bids already submitted may be withdrawn without penalty prior to bid opening. Errors discovered after bid opening may not be corrected. In the case of an error in price extension, the unit price will govern. The intention of the bidder must be evident on the face of the bid.
14. **HAZARDOUS AND TOXIC SUBSTANCES:** Bidder must comply with all applicable Federal, State, County and bi-county laws, ordinances and regulations relating to hazardous and toxic substances, including such laws, ordinances and regulations pertaining to access to information about hazardous and toxic substances, and as amended from time to time. Bidder shall provide the College with a "Material Safety Data Sheet" or in the case of a controlled hazardous waste substance, a hazardous waste manifest for all hazardous chemicals listed or subsequently added to the Chemical Information List in compliance with applicable laws, ordinances and regulations.
15. **INSPECTION OF PREMISES:** If a site visit is recommended or required, each bidder is responsible to visit the site(s) prior to submitting a bid in order to observe the existing conditions affecting the work, and to obtain precise dimensions of the area(s) involved. No allowance will be made to the successful bidder, at a later date, for additional work required because of his or her failure to visit the site and/or to obtain the exact dimensions. Discrepancies, if any, must be reported to the College.
16. **INSURANCE:** If a contract results from this bid, the contractor shall maintain such insurance as will indemnify and hold harmless the College from Workmen's Compensation and Public Liability claims for property damage and personal injury, including death, which may arise from the contractor's operations under this contract, or by anyone directly or indirectly employed by him/her.
17. **MARYLAND PUBLIC INFORMATION ACT:** Bidder recognizes that the College is subject to the Maryland Public Information Act, Title 10 of the State Government Article of the Annotated Code of Maryland. Bidder agrees that it will provide any justification as to why any material, in whole or in part, is deemed to be confidential, proprietary information or trade secrets and provide any justification of why such materials should not be disclosed pursuant to the Maryland Public Information Act.
18. **NON-ASSIGNMENT AND SUBCONTRACTING:** Bidder shall not assign any contract or any rights or obligations hereunder without obtaining prior written consent of the College. No contract shall be made by bidder with any other party for furnishing the services to be performed under a contract issued from this solicitation without the written approval of the College. These provisions will not be taken as requiring the approval of the contract of employment between bidder and its personnel.
19. **NON-COLLUSION:** Bidder certifies that it has neither agreed, conspired, connived, or colluded to produce a deceptive show of competition in the compilation of the bid or offer being submitted herewith; bidder also certifies that it has not in any manner, directly or indirectly, entered into any agreement, participated in any collusion to fix the bid price or price proposal of the bidder or offeror herein or any competitor, or otherwise taken any action in restraint of free competitive bidding in connection with the contract for which the within bid or offer is submitted.
20. **NON-DISCRIMINATION:** Bidder assures the College that, in accordance with applicable law, it does not, and agrees that it will not discriminate in any manner on the basis of sex, race, age, color, creed, national origin, religious belief, handicap, marital status, or status as a disabled veteran or veteran of the Vietnam era. Bidder further agrees to post in conspicuous places notices setting forth the provisions of the nondiscrimination clause and to take affirmative action to implement the provisions of this section. Bidder further assures the College that, in accordance with the Immigration Reform and Control Act of 1986, it does not and will not discriminate against an individual with respect to hiring, or recruitment or referral for a fee, of the individual for employment or the discharging of the individual from employment because of such individual's national origin or in the case of a citizen or intending citizen, because of such individual's citizenship status.
21. **PATENTS:** Bidder guarantees that the sale and/or use of the goods offered will not infringe upon any U.S. or foreign patent. Bidder will at his/her own expense, indemnify, protect and save harmless the College, its trustees, employees, agents and students with respect to any claim, action, cost or judgment for patent infringement, arising out of the purchase or use of these goods.
22. **PREPARATION OF BID:** Bids submitted must be hand signed by an authorized agent of the company submitting the bid. Notification of award will be made by "Notice of Intent to Award" and/or purchase order. A bidder may attach a letter of explanation to the bid for clarification. Bidders will be required, if requested by Montgomery Community College, to furnish satisfactory evidence that they are, in fact, bona fide manufacturers of or dealers in the items listed, and have a regularly established place of business. The College reserves the right to inspect any bidder's place of business prior to award of contract to determine bidder responsibility.
23. **PRODUCT TESTING DURING TERM OF CONTRACT:** Goods delivered under any contract resulting from this Request for Bid may be tested for compliance with specifications stipulated herein. Any shipment failing to meet or comply fully with the specification requirements will be rejected. The cost of testing a representative sample of an order or shipment for acceptance shall be borne by the College unless the order is rejected for failure to meet specifications or purchase description. In such cases of rejection, the cost of testing will be charged back to the vendor.
24. **RECORD RETENTION:** If awarded a contract, vendor shall maintain books and records relating to the subject matter of this Agreement, including but not limited to all charges to the College, for a period of three (3) years from the date of final payment under this Agreement.
25. **REJECTIONS AND CANCELLATIONS:** Montgomery Community College reserves the right to accept or reject any or all bids in whole or in part for any reason. The College reserves the right to waive any informalities and to make awards in the best interest of the College. The College also reserves the right to reject the bid of any bidder who has previously failed to perform adequately on a prior award for furnishing goods and/or services similar in nature to those requested in this bid. The College may cancel this solicitation in whole or in part, in its sole discretion.
26. **RIDER PROVISION FOR MONTGOMERY COUNTY PUBLIC SCHOOLS AND MONTGOMERY COUNTY:** The bidder agrees when submitting the bid that it will make available to every office and department of the Montgomery County Public Schools and the Montgomery County Government the same bid prices, terms and conditions offered during the term of contract. Orders will be placed directly by these agencies. There will be no penalty if bidder notes exception to this provision in the bid offered.
27. **SAMPLES AND CATALOG CUTS:** If samples are required, bidder shall be responsible for delivery of samples to location indicated. All sample packages shall be marked "Sample for Procurement Office, Bid No. ____" and each sample shall be tagged or marked. Failure of the bidder to clearly identify samples as indicated may result in rejection of bid. The College reserves the right to test any materials, equipment or supplies delivered to determine if the specifications have been met. Samples will not be returned.
28. **SIGNATURE:** Each bid must show the full business address and telephone number of the bidder and be signed by the person or persons legally authorized to sign such contracts. All correspondence concerning the bid and contract, including the bid summary, copy of contract, and purchase order, will be mailed or delivered to the address shown on the bid. **NO BID WILL BE ACCEPTED WITHOUT ORIGINAL SIGNATURE.**
29. **TAXES:** The College is exempt from Federal and Maryland taxes. Exemption Certificates are available upon request. Bidder shall be responsible for the payment of any and all applicable taxes resulting from any award and/or any activities hereunder, including but not limited to any applicable amusement and/or sales taxes.
30. **TERMINATION BASED ON LACK OF FUNDING:** Any contract awarded as a result of this solicitation will be subject to funding and continued appropriation of sufficient funds for the contract. For purposes of this solicitation, the College's appropriating authority is deemed to be the Board of Trustees of Montgomery Community College. Insufficient funds shall be grounds for immediate termination of this solicitation.
31. **TERMINATION FOR DEFAULT:** If an award results from this bid, and the contractor has not performed or has unsatisfactorily performed the contract, payment shall be withheld at the discretion of the College. Failure on the part of the contractor to fulfill contractual obligations shall be considered just cause for termination of the contract and the contractor is not entitled to recover any costs incurred by the contractor up to the date of termination.
32. **TERMINATION FOR THE CONVENIENCE OF THE COLLEGE:** The performance of the work or services under a contract as a result of this solicitation may be terminated in whole or in part, whenever the President of Montgomery Community College shall deem that termination is in the best interest of the College. Such determination shall be in the sole discretion of the President. In such event, the College shall be liable only for payment in accordance with the payment provisions of the contract for work or services performed or furnished prior to the effective date of termination. Termination hereunder shall become effective by delivery to contractor of written notice of termination upon which date the termination shall become effective.
33. **WARRANTY:** Bidder expressly warrants that all articles, material and work offered shall conform to each and every specification, drawing, sample or other description which is furnished to or adopted by the College and that they will be fit and sufficient for the purpose intended, merchantable, of good material and workmanship, and free from defect. Such warranty shall survive a contract and shall not be deemed waived either by the College's acceptance of said materials or goods, in whole or in part, or by payment for them, in whole or in part. The bidder further warrants all articles, material and work performed for a period of one year, unless otherwise stated, from date of acceptance of the items delivered and installed, or work completed. All repairs, replacements or adjustments during the warranty period shall be at bidder's sole expense.

INSTRUCTIONS FOR BIDDERS**MONTGOMERY COLLEGE****SCIENCE & APPLIED STUDIES BUILDING
TEMPORARY CLAY TILE ROOF REPAIR
GERMANTOWN CAMPUS****PART 1 - PRE-BID CONFERENCE**

- 1.1 A Pre-Bid Conference/Site Inspection will be held on November 3, 2009 **at 2:00 P.M.** in Room 105, Goldenrod Building, 20271 Goldenrod Lane, Germantown, MD 20876-4064. Attendance by all bidders is strongly encouraged.
- 1.2 **Examination of Existing Conditions:**
Bidders are advised to examine and investigate existing site conditions prior to bid. Access to the site and/or College records may be obtained by contacting:

Eric koh, AIA, College Architect**Phone: 240-567-7364****Fax: 240-567-7379**

Montgomery College

Office of Central Facilities

40 West Gude Drive, Suite 200

Rockville, MD 20850

PART 2 - PREPARATION OF BIDS

- 2.1 Bids must be submitted on the enclosed Bid Form and must include all the attachments listed on the Bid Form. Bids must be signed by an authorized officer of the firm. Blank spaces must be filled in, either in ink or typewritten, both in words and figures. The person signing the bid must initial erasures on or changes to the forms.
- 2.2 Each bid must be submitted in a sealed envelope. Bidders must copy and paste the following bid envelope sample label on the outside of their envelope for each bid submitted. It is mandatory that the bid envelope label is used or this exact information is provided on the envelope of the sealed bid. Failure to do so may cause the bid to be rejected. Any bid received after the time and date specified, or at a different location than specified above, will not be opened or given any consideration.

Bid Envelope Label	
Bid Number:	_____
Bid Title/Description:	_____
Bid Opening Date:	_____
Bid Opening Time:	_____
Bidder's Name:	_____
Bidder's Address:	_____
Bidder's Phone Number:	_____

PART 3 - DELAYED OPENING

- 3.1 If Montgomery College is closed for any reason on the scheduled day of the bid opening, the bid will be opened on the next business day, at the same stated opening time, unless other notification is provided.

PART 4 - WITHDRAWAL OF BIDS

- 4.1 Bidder may not withdraw or modify the bid for ninety (90) calendar days after the bid opening.

PART 5 - AWARD OR REJECTION OF BIDS

- 5.1 The contract will be awarded in consideration of Base Bid price and the substantiated ability of the apparent low responsible Bidder to perform the required services described in these Bidding Documents. The award will be made subject to the availability of public funds and only if it is in the best interest of the College to accept the bid. The College reserves the following rights to be exercised at the College's sole discretion:
- A. To make such investigation as deemed necessary to determine the qualifications of the Bidder and to determine the ability of the Bidder to perform the work. The Bidder shall furnish to the College all such information and data as the College may request. The College reserves the right to reject any bid if the evidence submitted by, or investigation of, such Bidder fails to satisfy the College that such Bidder is properly qualified to carry out the obligations of the contract and to complete the work contemplated herein. The College reserves the right to restrict bidding to such Bidders who the College determines are qualified by experience and finances to successfully carry out the Work.
 - B. Conditional bids will not be accepted.
 - C. To reject any or all bids and to make awards in the best interest of the College, in the name of the Board of Trustees. The College also reserves the right to cancel the Request for Bid.
 - D. To accept or reject any item of bid or any alternate prices in the priority order established by the Bid Form.
 - E. To consider informal, any bid not prepared or submitted in accordance with the provisions hereof. The College may at its sole discretion waive any informality. A waiver of any provision of the Bidding Documents shall not constitute a waiver of any subsequent breach.
 - F. To defer award of the contract for a period of up to ninety (90) calendar days after opening of bids. If no award or other disposition is made, the expiration of the ninety (90) calendar days will constitute rejection of all bids without any further action by the College.

PART 6 - BIDDING DOCUMENTS

- 6.1 Bidding Documents include the Request for Bid, Instructions to Bidders, Information Available to Bidders, Supplementary Information and Conditions, Preliminary Project Schedule, Required Submissions, Bid Form and attachments thereto, Form of Contract, Performance and Payment Bonds (if required), General Conditions, Specifications, Drawings and all Addenda.

- 6.2 The Bid Documents may be obtained at Montgomery College's Office of Central Facilities, 40 West Gude Drive, Suite 200, Rockville, MD 20850 on or after October 28, 2009. Payment of a non-refundable fee in the amount of Ten Dollars, plus any applicable delivery charges, is required. An electronic bid documents in PDF format may be obtained by downloading the file from the procurement website <http://www.montgomerycollege.edu/departments/procure/> at no charge.
- 6.3 Bidding Documents will be available for reference at the following location on or after October 28, 2009:
- Montgomery College Office of Central Facilities
40 West Gude Drive, Suite 200
Rockville, Maryland 20850
Attn: Cindy Orelli
Phone No.: 240-567-7363

PART 7 - EXAMINATION OF SITE AND BIDDING DOCUMENTS

- 7.1 Bid submission shall serve as verification that, at the time of receipt of the bids, the Bidder has inspected the site and has read and is thoroughly familiar with the Bidding Documents (including all Addenda); has examined and finds the Specifications and the Drawings adequate; and agrees that what the Specifications and Drawings require, in any part of the Work, the required result can be produced. Failure or omission of a Bidder to inspect the site or to examine any form, instrument or document shall in no way relieve a Bidder from obligation in respect to his/her Bid.
- 7.2 Data in the Bidding Documents pertaining to existing conditions is for convenience only and does not supplant obtaining first-hand information at the site. Submission of a Bid shall constitute acceptance by the Bidder of existing site conditions as a part of the requirements for this work.

PART 8 - INTERPRETATION OR CORRECTION OF BIDDING DOCUMENTS

- 8.1 The Bidding Documents should be examined carefully. Should any Bidders find discrepancies or omissions in these Bidding Documents, or be in doubt as to the meaning of any item(s), they should submit requests for clarification, in writing to:
- Eric Koh, AIA. College Architect
Phone: 240-567-7364
Fax: 240-567-7379
E-mail: eric.koh@montgomerycollege.edu
- 8.2 Bidders shall be responsible for reviewing and coordinating the submission of clarifications requested by Subcontractors or Vendors. Clarification requests made directly by Subcontractors or Vendors will not be accepted by the College.
- 8.3 REQUESTS FOR CLARIFICATIONS BY BIDDERS MUST BE SUBMITTED IN WRITING NO LATER THAN 5:00 PM ON NOVEMBER 9, 2009.

- 8.2 Bidders shall not communicate directly with the Architect/Engineer or any of the Architect/Engineer's consultants. No interpretation of the meaning of Bidding Documents will be made to any Bidder orally as oral instruments do not form a part of the Bidding Documents.
- 8.3 The College will review the written questions and requests for clarification, if any, and any and all such interpretations and any supplemental instructions will be in the form of written Addenda to the Contractor Qualification documents which, if issued, may be obtained by downloading the file from the procurement website <http://www.montgomerycollege.edu/departments/procure/> at no charge.
- 8.4 Notification regarding addenda posting will be provided by e-mail, to all Bidders who are known by the College to have received a complete set of bid documents and who have provided an accurate current e-mail address. To ensure that an accurate notification attempt can be made, all Bidders are advised to register their contact information with the College to:
- Bid No. 610-006
Attn: Cindy Orelli
Montgomery College, Office of Central Facilities
40 West Gude Drive, Suite 200
Rockville, Maryland 20850
Phone No.: 240-567-7363
Fax No. 240-567-7379
- 8.5 It is the Bidder's sole responsibility to ensure receipt of all Addenda. It is highly recommended that the Bidder check the College's website for all posted Addenda prior to submitting their bid. All Addenda shall become part of the contract documents.
- 8.6 Failure of any Bidder to receive any such Addenda or interpretation shall not relieve such Bidder from any obligation under his/her bid as submitted.
- 8.7 If conflicts, discrepancies, ambiguities, or omissions in, or between, the Bidding Documents, site conditions, etc., are not brought to the attention of the College during the time for bidding, the interpretation and intent of the Bidding Documents shall be as determined by the College in its sole discretion. In such an instance the decision of the College shall be binding and no claims for extra costs will be entertained.

PART 9 - BID FORMS

- 9.1 Each bid must be submitted on the prescribed forms with all attachments as defined in the BID FORM contained in these Bidding Documents. All blank spaces for bid prices must be filled in, in ink or typewritten, in both words and figures. The words "No Bid" in any of the spaces constituting a bid price as well as a qualified bid price may cause the entire bid to be rejected.
- 9.2 Bid shall be signed in longhand below the typed name of the person authorized to bind the Bidder to the contract.
- 9.3 When Bidder is a corporation, bid must be signed with the legal name of the corporation followed by the name of the State of incorporation and the legal signature of a person authorized to bind the corporation to a contract.

PART 10 - BONDS AND CONTRACTS

- 10.1 Bidder shall furnish a Bid Bond and Letter of Intent from Bonding Company (provide original and two copies of forms, letters and authorizations) as required below.

- 10.2 Each bid must be accompanied by an original and two copies of a Bid Bond from a surety company authorized to do business in the State of Maryland, acceptable to the College, made payable without condition to the College, for not less than 10% of the amount of the Base Bid, or a cashier's check in the amount of not less than 10% of the Base Bid amount. Upon request, Bid Bonds will be returned to all Bidders after the College and the accepted Bidder have executed a contract, or if no contract has been executed within ninety (90) calendar days after the bid due date, upon demand of the Bidder at any time thereafter so long as he/she has not been notified of the acceptance of his bid. Bid Bond shall be prepared on AIA Form A310, "BID BOND".
- 10.3 Bidder shall furnish a letter from the Bidder's bonding company by which letter it guarantees that it will furnish the required 100% performance and labor and material payment bonds if award of contract is made to Bidder.
- 10.4 The successful Bidder, upon his/her failure or refusal to execute and deliver the Contract and bonds required within five (5) days, Saturdays, Sundays and legal holidays excluded, after he/she has received notice of the acceptance of his bid, shall forfeit to the College, as liquidated damages for such failure or refusal, the security deposited with his/her Bid.
- 10.5 If at any time, the Bonding Company becomes insolvent, files for bankruptcy or for any reason whatsoever loses its right to do business in the State of Maryland, the Contractor shall, within ten (10) calendar days after notice from the College to do so, substitute an acceptable Bond (or bonds) in such form and sum and signed by such other Bonding Company as may be satisfactory to the College.

PART 11 - PERFORMANCE, LABOR AND MATERIALS BOND

- 11.1 Prior to the execution of the contract, the successful Bidder shall deliver to the College a performance and labor and materials payment bond, properly executed on the Montgomery College Standard Performance Bond a copy of which is enclosed in these Bidding Documents, for 100% of the amount of his/her contract.

PART 12 - POWER OF ATTORNEY

- 12.1 Attorneys-in-fact who sign bid bonds or contract bonds must file with each bond, a certified and effectively dated copy of their power of attorney.

PART 13 - FORM OF CONTRACT

- 13.1 The College's standard Purchase Order form will be used.

PART 14 - CONTRACTOR'S QUALIFICATIONS

- 14.1 Bidders shall submit to the College, along with their bid:
- a) At least three project references, including two projects within the Metropolitan Baltimore-Washington region, documenting successful completion of projects of similar size, scope and complexity, within the last five years.

PART 15 - SUBCONTRACTOR'S QUALIFICATIONS

- 15.1 Within three business days of request by the College, Bidders shall provide names, addresses, Maryland registration/license number and indication of minority status, for all the Subcontractors proposed to be retained by the Contractor for this project;
- 15.2 Bidders shall submit to the College additional information for each Principal Subcontractor, herein defined as those Subcontractors whose contract value is anticipated to exceed \$ 100,000:
- a) Type of work performed;
 - b) Years in business;
 - c) Representative Project List and References (list at least three projects of similar size, scope, and complexity and references including contact name and telephone number);
 - d) Copy of Maryland registration/license number, if applicable.
- 15.3 The College's intent with regard to Subcontractor financial stability is that it is the Contractor's responsibility to evaluate the financial viability and solvency of all Subcontractors.
- 15.4 The College reserves the right to reject any Subcontractor.

PART 16 - VENDOR QUALIFICATIONS (Not Used)**PART 17 - INSURANCE**

- 17.1 Before starting any work, the Contractor must provide sufficient evidence of insurance showing adequate coverage as defined in the General Conditions included in this bid request. If a contract amount is greater than \$3,000,000, the requirement for commercial general liability insurance shall increase to the corresponding million. If a contract amount is less than \$1,000,000, the requirement for commercial general liability insurance shall be reduced to \$1,000,000.

PART 18 - LAWS AND REGULATIONS

- 18.1 The Bidder's attention is directed to the fact that all applicable Federal and State laws, County, Bi-County, local, and municipal ordinances, and the orders, rules and regulations of all authorities having jurisdiction over this work shall apply to the contract throughout, and they will be deemed to be included in the contract the same as though herein written out in full.

PART 19 - MINORITY PARTICIPATION

- 19.1 Pursuant to Board Resolutions #87-82 and #87-83, adopted on July 20, 1987, it is the policy of Montgomery College to encourage minority businesses to provide goods and services for the performance of College functions. Minority businesses include non-profit entities organized to promote the interests of handicapped persons, and firms that are 51% owned and controlled by a member(s) of socially or economically disadvantaged minority group, which includes: blacks, Hispanics, American Indians, Alaska natives, Asians, Pacific islanders, women, and the mentally or physically disabled.

- 19.2 The Bidder must submit the College's Minority Participation Form, included in the contract documents, with their Bid.
- 19.3 The Bidder is encouraged to demonstrate that at a minimum 15% of the subcontractors and/or vendors anticipated to be retained by the Bidder for the College's project are minority firms.

End of Instructions for Bidders

This Page is Intentionally Left Blank

SUPPLEMENTARY INFORMATION AND CONDITIONS**MONTGOMERY COLLEGE****SCIENCE & APPLIED STUDIES BUILDING
TEMPORARY CLAY TILE ROOF REPAIR
GERMANTOWN CAMPUS****PART 1 - AWARD SCHEDULE**

- 1.1 It is the College's intention to seek approval of award of this contract to the lowest responsive and responsible Bidder at the December 14, 2009 meeting of the College's Board of Trustees. If the contract amount is less than \$100,000.00, an award will be made immediately following receipt and evaluation of the Bids.
- 1.2 Notwithstanding this expectation, the College may require additional time to administer the College and/or State contract award or other processes. To accommodate for this possibility, bid prices must remain firm for 90 days from proposal due date. It is the Contractor's sole responsibility to ensure that his/her Bid accommodates this requirement.
- 1.3 Notice to Proceed (NTP) will be timely provided upon receipt of Contractor materials required before work start, including but not limited to Bonds and Insurance certificates.

PART 2 - CONTRACTOR QUALIFICATION AND EVALUATION

- 2.1 The Contractor, hereby, assures the College that the Contractor and its Subcontractors and Vendors are fully qualified to perform the services provided for in these Bidding Documents in accordance with all applicable laws, orders, rules and regulations. The Contractor further assures the College that the Contractor and its Subcontractors and Vendors are free from any financial interests which may conflict with the proper performance of this Agreement.
- 2.2 The Contractor and its Subcontractors and Vendors are required to have engaged in providing successful construction services of similar size, complexity and scope within the Baltimore and Washington Metropolitan area of a period of not less than five (5) years.
- 2.3 The Contractor and its Subcontractors and Vendors shall have currently in their employ, sufficient staff to provide the required work per the Bidding Documents.

PART 3 – PRELIMINARY PROJECT SCHEDULE

- 3.1 The successful bidder shall provide the College with a construction schedule within five (5) days of notice to proceed.

- 3.2. All work included herein shall be completed within two (2) months of Notice to Proceed.
- 3.3. Tear-off should be restricted to early hours so as to minimize the noise impact of the project. Weekend works maybe required in certain areas to avoid disruptions to the occupants.
- 3.4. The purpose of this schedule is to outline general guidance with respect to anticipated overall contract duration and the anticipated sequence and duration of the Work. Within the context of the overall schedule expectation, the Contractor may propose alterations to interim milestones and sequencing as necessary to suit project means, methods and conditions, subject to review and approval by the College.

End of Supplementary Information and Conditions

REQUIRED SUBMISSIONS**MONTGOMERY COLLEGE****SCIENCE & APPLIED STUDIES BUILDING
TEMPORARY CLAY TILE ROOF REPAIR
GERMANTOWN CAMPUS**

TO: PROSPECTIVE BIDDERS

**FROM: PROCUREMENT OFFICE
MONTGOMERY COMMUNITY COLLEGE**

Bids (**original and two copies including all attachments**) shall be submitted on the enclosed Bid Form, properly signed with the required attachments, if any, in sealed envelopes and addressed to:

**Director of Procurement
Montgomery Community College
900 Hungerford Drive, Room 110
Rockville, MD 20850**

Bidder shall refer to Part 2, of Instruction For Bidders for bid preparation requirements.

PART 1 - ITEMS REQUIRED FOR ALL BID SUBMISSIONS:

- A. Bid Form.
- B. Minority Participation Form for Bidder.
- C. Project Reference List for Bidder.

It is mandatory that a Project Reference List for Bidder be submitted as an attachment to the Bid Form and become a part thereof for the Contractor submitting a bid for this project. The College will use information provided by the Bidder in this form to determine Bidder's qualifications as well as adequacy of resources to perform the Work for this project. The Bidder must list and describe previous experience by the Bidder in providing related services on similar projects of no less than the size and scope of this roof repair project, within the past five (5) years, in the Baltimore and Washington Metropolitan areas, in order to demonstrate that the Bidder is familiar with the size, complexity and scope of the work described as well as with local labor forces and regulatory agencies.

- D. AIA Form A310, Bid Bond.
- E. Bonding Company Letter Guaranteeing the Required 100% Performance, Labor and Material Payment Bonds.
- F. Copy of Maryland Contractor License for Contractor
- G. Contractor's Management/Supervisory Personnel List including the Construction Superintendent.

The Bidder shall list the names and describe previous experience by the overall Construction Superintendent and the personnel who will be assigned to the College's project in providing project management and supervision services for construction projects of similar size, complexity

and scope together with a statement as to the extent to which these personnel will be full-time or part-time.

H. Project Schedule Confirmation Statement.

Include statement acknowledging that the Preliminary Project Schedule is acceptable to the Contractor.

PART 2 – PREPARATION OF BID PROPOSALS

- A. Bidders shall supply all data required on the enclosed forms. Proposals shall be typewritten, printed or clearly written in ink.
- B. The person signing the bid must initial erasures on or changes to the forms.
- C. Bid Form must include an **original and two copies** of the documents and materials requested below. Failure to include all the documents may render the proposal non-responsive and the offer may be rejected.

End of Required Submissions

BID FORM

MONTGOMERY COLLEGE

**SCIENCE & APPLIED STUDIES BUILDING
TEMPORARY CLAY TILE ROOF REPAIR
GERMANTOWN CAMPUS**

To: Montgomery College

Re: Science & Applied Studies Building
Temporary Clay Tile Roof Repair
Germantown Campus

Attn.: Procurement Office
Montgomery Community College
900 Hungerford Drive – Room 110
Rockville, Maryland 20850

From: _____
(Provide Your Company's Name)

PART 1 - The undersigned (hereinafter referred to as Contractor) proposes to provide all of the necessary labor, materials, equipment, and insurance for the Temporary Clay Tile Roof Repair at the Montgomery College Germantown Campus, as specified in the attached construction documents. The work to be performed by the Contractor shall include all items accepted by the College as part of the Contractor's bid submittal and base bid. It is understood that Montgomery College (hereinafter referred to as College) will be the sole judge as to the acceptance of the bids and award of the contract. All work shall be done in accordance with the accompanying Specifications and Drawings for the amount listed below for **Base Bid** as applicable in accordance with the terms of the Contract Documents.

PART 2 - Please read the questions, note what is requested, then provide appropriate responses. Failure to answer any of the applicable questions contained in this section will make the bid non-responsive and grounds for rejection of the entire bid. **Conditional bids will not be accepted.**

Bidder must submit original plus two copies of the Bid Form and all attachments (see PART 9 – Bid Submittal Attachments).

PART 3 - Bidder acknowledges receipt of the following addenda:

Number _____ Date _____

Number _____ Date _____

Number _____ Date _____

Number _____ Date _____

PART 4 - BASE BID: (State amounts in both words and numbers)

The proposed total contract amount to complete the Temporary Clay Tile Roof Repair at the Germantown Campus, including the cost associated with Performance, Labor and Material Payment Bonds, and including the cost associated with any Separately Identified Price, and predetermined quantities of Unit Price Items to be included in the project, if requested in Part 5 below, in accordance with the Contract Documents, and having examined both the Place of the Work and all matters referred to in the Bid Documents, is:

Base Bid:

(In Words): _____ Dollars

(In Numbers): \$ _____

PART 5 - SPECIAL PRICING REQUIREMENTS:

A. UNIT PRICES

Provide unit prices to establish a fixed basis for costs for adding or changing specified quantities of work from those indicated in the contract drawings and specifications, when directed in writing by the College to make such changes. The unit prices shall include all labor, materials, equipment, overhead, bonds, insurance and profit and shall either be added to or subtracted from the quantity of this type of work specified as a result of field conditions. Include 400 S. F. in the base bid.

Unit Price No. 1 – Removal and replacement of deteriorated gypsum plank decking.

Add/Deduct Unit Price: (In Words): _____ Dollars per S.F.

(In Numbers): \$ _____ /S.F.

PART 6 - BID SURETY

A. The bid surety attached in the sum of _____ Dollars (\$ _____) is to become the property of the College in the event the Contract and Bond are not executed with the time set forth, as liquidated damages for the delay and additional expense to the College caused thereby.

B. The undersigned includes the following submissions as part of the Bid Form:

- Bid Bond (AIA Form A310, "Bid Bond")
- Bonding Company Letter

PART 7 - ACCEPTANCE OF BIDS

The undersigned acknowledges the right of the College in its sole discretion to accept any Bid or to reject any or all Bids.

PART 8 - BIDDER'S PROJECT REFERENCES

The Bidder shall list at least three projects of similar scope, size and complexity. At least two of the project sites are to be within the Metropolitan Baltimore-Washington area. The referenced work shall have been completed within the last five years. Provide a brief description of the scope of work. Please make sure your references and contact persons are current. Use separate sheets if necessary and include with your submission. These will become part of the contract.

REFERENCE #1:

Name and Address of Project: **Name of Contact Person: Telephone:** **Contract Value:**

Date & Description:

REFERENCE #2:

Name and Address of Project: **Name of Contact Person: Telephone:** **Contract Value:**

Date & Description:

REFERENCE #3:

Name and Address of Project: **Name of Contact Person: Telephone:** **Contract Value:**

Date & Description:

PART 9 - BID SUBMITTAL ATTACHMENTS

(Submit Original plus Two Copies of the Bid Form and all Attachments)

- A. Minority Participation Form
- B. AIA Form A310, Bid Bond
- C. Bonding Company Letter Guaranteeing the Required 100% Performance, Labor and Material Payment Bonds
- D. Copy of Maryland Contractor License for Contractor
- E. Contractor's Management/Supervisory Personnel List including the Construction Superintendent
- F. Project Schedule Confirmation Statement. Include statement acknowledging that the Preliminary Project Schedule is acceptable to Contractor.
- G. Bidder's Project References (if separate sheets are provided beyond the Bid Form)

PART 10 - The undersigned agrees that if he/she is selected as the Contractor he/she will, within five (5) days, Saturdays, Sundays and legal holidays excluded, after presentation thereof by the College, execute a Contract in accordance with the terms of this Bid Solicitation and Contract Documents.

PART 11 - The Bidder proposes to provide labor and materials and allowances to complete the Work, as specified in the Contract Documents. The Bidder is reasonably expected, given the existing conditions and required construction, to complete the Work within the completion date stated in the Contract Documents.

PART 12 - The undersigned further certifies under the penalties of perjury that this bid is in every respect bona-fide, fair and made without collusion or fraud with another person, joint venture, corporation, partnership or other business or legal entity.

PART 13 - SIGNATURES:

(Date)

(Company Name)

(Address)

(Telephone Number)

(Facsimile Number)

By:
SEAL IF A CORPORATION

Authorized Agent & Title (Print)

Signature

(F.I.N.)

(Contractor License Number)

BE SURE YOU SIGN YOUR BID

This Page is Intentionally Left Blank

BID BOND

MONTGOMERY COLLEGE

**SCIENCE & APPLIED STUDIES BUILDING
TEMPORARY CLAY TILE ROOF REPAIR
GERMANTOWN CAMPUS**

Use AIA Document A310, Bid Bond, latest edition, unless otherwise indicated

This Page is Intentionally Left Blank

MINORITY PARTICIPATION FORM

MONTGOMERY COLLEGE

**SCIENCE & APPLIED STUDIES BUILDING
TEMPORARY CLAY TILE ROOF REPAIR
GERMANTOWN CAMPUS**

BIDDERS SHALL COMPLETE THE FOLLOWING:

I HEREBY REPRESENT THAT OUR/MY FIRM IS _____

IS NOT _____

A MINORITY BUSINESS FIRM AS INDICATED BELOW (circle one):

**Black (not Hispanic) _____ Hispanic _____ Asian/Pacific Islander _____
American Indian/Alaska native _____ Disabled _____ Female _____**

I hereby certify that the above information is true and correct, to the best of my knowledge and belief.

Firm Name

Signed **Date**

Type or Print Name

Title

This Page is Intentionally Left Blank

PROCUREMENT OFFICE QUESTIONNAIRE

MONTGOMERY COLLEGE

**SCIENCE & APPLIED STUDIES BUILDING
TEMPORARY CLAY TILE ROOF REPAIR
GERMANTOWN CAMPUS**

**MONTGOMERY COLLEGE
Procurement Office**

RFB Number: _____

RFB Title: _____

Please be advised that our company **does not** wish to submit a bid in response to the above-captioned Request for Bid for the following reasons:

- Too Busy at this time
- Not engaged in this type of work
- Project too large/ small
- Cannot meet mandatory specifications (Please specify below)
- Other (Please specify)

SIGNATURE

PRINTED NAME

TITLE

DATE

COMPANY

Address

Please return to:
Montgomery Community College
Procurement Office
900 Hungerford Drive, Room 110
Rockville, Maryland 20850-1733

This Page is Intentionally Left Blank

Montgomery College
Standard Performance Bond

Any singular reference to Contract, Surety, Owner or Other Party shall be considered plural where applicable.

CONTRACTOR (*Name and Address*):

SURETY (*Name and Principle Place of Business*):

OWNER (*Name and Address*):

CONSTRUCTION CONTRACT

Date:

Amount:

Description (Name and Location):

BOND

Date (Not earlier than Construction Contract Dated):

Amount:

Modifications to this Bond:

CONTRACTOR AS PRINCIPAL

Company:

(Corporate Seal)

None

SURETY

Company:

See Page 3

(Corporate Seal)

Signature: _____

Name and Title:

Signature: _____

Name and Title:

(Any additional signatures appear on the last page)

(FOR INFORMATION ONLY – Name, Address and Telephone)

AGENT or BROKER:

OWNER'S REPRESENTATIVE (Architect, Engineer or other party)

1 The Contractor and the Surety, jointly and severally, bind themselves, their heirs, executors, and administrators, successors and assigns to the Owner for the performance of the Construction Contract, which is incorporated herein by reference.

2 If the Contractor performs the Construction Contract in accordance with its terms, the Surety and the Contractor shall have no obligation under this Bond.

3 Whenever the Contractor shall be declared by the Owner to be in default under the Contract, the Surety shall, at its sole expense, within 15 days after Owner having mailed to Surety a copy of the notice of default sent to Contractor, take one of the following actions:

3.1 Arrange for the Contractor, with consent of the Owner, to perform and complete the Construction Contract; or

3.2 Undertake to perform and complete the Construction Contract itself, through its agents or through independent contractors; or

3.3 Obtain bids or negotiated proposals from qualified contractors acceptable to the Owner for a contract for performance and completion of the Construction Contract, arrange for a contract to be prepared for execution by the Owner and the contractor selected with the Owner's concurrence, to be secured with performance and payment bonds executed by a qualified surety equivalent to the bonds issued on the Construction Contract, and pay to the Owner the amount of damages as described in Paragraph 5 in excess of the Balance of the Contract Price incurred by the Owner resulting from the Contractor's default; or

3.4 Waive its right to perform and complete, arrange for completion, or obtain a new contractor and

.1 After investigation, determine the amount for which it may be liable to the Owner and, as soon as practicable after the amount is determined, tender payment therefor to the Owner; or

.2 Deny liability in whole or in part and notify the Owner citing reasons therefor.

4 If the Surety does not proceed as provided in Paragraph 3, the Surety shall be deemed to be in default on this Bond fifteen days after receipt of an additional written notice from the Owner to the Surety demanding that the Surety perform its obligations under this Bond, and the Owner shall be entitled to enforce any remedy

available to the Owner. If the Surety proceeds as provided in Subparagraph 3.4, and the Owner refuses the payment tendered or the Surety has denied liability, in whole or in part, without further notice the Owner shall be entitled to enforce any remedy available to the Owner.

5 After the Owner has terminated the Contractor's right to complete the Construction Contract, and if the Surety elects to act under Subparagraph 3.2 or 3.3 above, then the responsibilities of the Surety to the Owner shall not be greater than those of the Contractor under the Construction Contract. The Surety is obligated without duplication for:

5.1 The responsibilities of the Contractor for correction of defective work and completion of the Construction Contract;

5.2 Additional legal, design professional and delay costs resulting from the Contractor's Default, and resulting from the actions or failure to act of the Surety under Paragraph 3;

5.3 Liquidated damages, or if no liquidated damages are specified in the Construction Contract, actual damages caused by delayed performance or non-performance of the Contractor, and

5.4 All other costs and damages permitted to be recovered by the Owner under the Construction Contractor at law.

6 The Surety hereby waives notice of any change, including changes of time, to the Construction Contract or to related subcontracts, purchase orders and other obligations.

7 Any proceeding, legal or equitable, under this Bond may be instituted only in the Circuit Court for Montgomery County, Maryland and the Surety waives venue in any other court.

8 Notice to the Surety, the Owner or the Contractor shall be mailed or delivered to the address shown on the signature page.

9 This Bond had been furnished to comply with a statutory or other legal requirement of the State of Maryland. Any provision in this Bond conflicting with said statutory or legal requirement shall be deemed deleted herefrom and provisions conforming to such statutory or other legal requirement shall be deemed incorporated herein. The intent is that this Bond shall be construed as a statutory bond and not as a common law bond.

to or on behalf of the Contractor under the Construction Contract.

10 DEFINITIONS

10.1 Balance of the Contract Price: The total amount payable by the Owner to the Contractor under the Construction Contract after all proper adjustments have been made, including allowance to the Contractor of any amounts received or to be received by the Owner in settlement of insurance or other claims for damages to which the Contractor is entitled, reduced by all valid and proper payments made

10.2 Construction Contract: The agreement between the Owner and the Contractor identified on the signature page, including all Contract Documents and changes thereto.

10.3 Contractor Default: Failure of the Contractor, which has neither been remedied nor waived, to perform or otherwise to comply with the terms of the Construction Contract.

(Space is provided below for additional signatures of added parties, other than those appearing on the cover page.)

CONTRACTOR AS PRINCIPAL
Company: (Corporate Seal)

SURETY
Company: (Corporate Seal)

Signature: _____
Name and Title:
Address:

Signature: _____
Name and Title:
Address:

This Page is Intentionally Left Blank

PAYMENT BOND

MONTGOMERY COLLEGE

**SCIENCE & APPLIED STUDIES BUILDING
TEMPORARY CLAY TILE ROOF REPAIR
GERMANTOWN CAMPUS**

Use AIA Document A312, Payment Bond, latest edition, unless otherwise indicated

This Page is Intentionally Left Blank

APPLICATION AND CERTIFICATE FOR PAYMENT

MONTGOMERY COLLEGE

**SCIENCE & APPLIED STUDIES BUILDING
TEMPORARY CLAY TILE ROOF REPAIR
GERMANTOWN CAMPUS**

Use AIA Document G702, Application and Certificate for Payment, latest edition, unless otherwise indicated

This Page is Intentionally Left Blank

**MONTGOMERY COLLEGE
GENERAL CONDITIONS OF THE CONTRACT**

TABLE OF CONTENTS

- 1. GENERAL PROVISIONS**
 - 1.1. DEFINITIONS
 - 1.2. CONTRACT DOCUMENTS
 - 1.2.1. Correlation and Intent of Contract Documents
 - 1.2.2. Specifications Format
 - 1.2.3. Standard Specifications
 - 1.2.4. Ownership

- 2. COLLEGE AND COLLEGE'S AGENTS**
 - 2.1. AUTHORITY OF THE COLLEGE'S REPRESENTATIVE
 - 2.2. RESPONSIBILITY OF THE COLLEGE'S REPRESENTATIVE AND/OR CONSTRUCTION MANAGER
 - 2.3. RESPONSIBILITIES OF THE ARCHITECT/ENGINEER
 - 2.4. COLLEGE'S RIGHT TO STOP OR SUSPEND WORK
 - 2.3.1. Stopping of the Work
 - 2.3.2. Suspension of the Work

- 3. CONTRACTOR**
 - 3.1. RESPONSIBILITIES OF THE CONTRACTOR
 - 3.2. CONTRACTOR'S ADMINISTRATION AND SUPERVISION OF THE WORK
 - 3.2.1. Staff
 - 3.2.2. Supervision
 - 3.2.3. Subcontracts
 - 3.2.4. Behavior of Contractor's Employees, Agents and Subcontractors
 - 3.3. MATERIALS, LABOR, EQUIPMENT AND PROCESSES
 - 3.3.1. Proposals
 - 3.3.2. Labor, Materials and Equipment
 - 3.3.3. Or Equal
 - 3.3.4. Substitutions
 - 3.3.5. Required List of Materials and Equipment
 - 3.4. WARRANTY/GUARANTEES
 - 3.5. TAXES
 - 3.6. PERMITS, FEES AND NOTICES
 - 3.7. PROSECUTION AND PROGRESS OF THE WORK
 - 3.7.1. Notice to Proceed
 - 3.7.2. Hours of Work
 - 3.7.3. Construction Schedule
 - 3.7.4. Progress Meetings
 - 3.8. REFERENCE DOCUMENTS FOR THE WORK
 - 3.8.1. Progress Documents
 - 3.8.2. Record Documents
 - 3.9. SHOP DRAWINGS, PRODUCT DATA AND SAMPLES

 - 3.10. SITE ACCESS, USE AND RESTRICTIONS
 - 3.10.1. Campus Coordination Requirements
 - 3.10.2. Coordination where Work is in or adjacent an Occupied Existing Building
 - 3.10.3. Temporary Facilities
 - 3.10.4. Existing Utilities

- 3.10.5. Erosion Control
- 3.10.6. Tree and Plant Protection
- 3.10.7. Snow and Ice Removal
- 3.10.8. Project Signage
- 3.11 HAZARDOUS AND TOXIC SUBSTANCES
 - 3.11.1. Hazardous and Toxic Substances
 - 3.11.2. Asbestos-Containing Materials
 - 3.11.3. Environmental Litigation
- 3.12 CUTTING AND PATCHING
- 3.13 CLEANING
 - 3.13.1. Progress Cleaning
 - 3.13.2. Final Cleaning
- 3.14 ROYALTIES AND PATENTS
- 3.15 INDEMNIFICATION

- 4. ADMINISTRATION OF THE CONTRACT**
 - 4.1 CLARIFYING INSTRUCTIONS
 - 4.2 REQUESTS FOR INFORMATION
 - 4.3 SITE VISITS AND OBSERVATIONS
 - 4.4 CLAIMS AND DISPUTES
 - 4.5 DELAYS AND DAMAGES

- 5. CONSTRUCTION BY COLLEGE OR BY SEPARATE CONTRACTORS**

- 6. CHANGES IN THE WORK**
 - 6.1 CHANGES IN THE WORK
 - 6.1.1 Changes
 - 6.1.2 Disputed Work
 - 6.1.3 Modification of Contract Sum
 - 6.1.4 Minor Changes in the Work

- 7. PAYMENTS AND COMPLETION**
 - 7.1 SCHEDULE OF VALUES
 - 7.2 PROGRESS PAYMENTS
 - 7.3 ACCEPTANCE OF THE WORK AND FINAL PAYMENT
 - 7.4 ASSIGNMENT OF CONTRACT MONIES
 - 7.5 AUDIT

- 8. PROTECTION OF PERSONS AND PROPERTY**
 - 8.1 SAFETY PRECAUTIONS AND PROGRAMS
 - 8.2 SAFETY OF PERSONS AND PROPERTY
 - 8.3 FIRE PROTECTION
 - 8.4 EMERGENCIES
 - 8.5 ACCIDENTS

- 9. INSURANCE AND BONDS**
 - 9.1. INSURANCE
 - 9.2. PERFORMANCE, LABOR AND MATERIAL BONDS

- 10. CORRECTION OF WORK**
 - 10.1 CORRECTION OF WORK
 - 10.1.1 Correction of Work before Final Payment
 - 10.2.1 Correction of Work after Final Payment
 - 10.2 ACCEPTANCE OF NON-CONFORMING WORK

11. MISCELLANEOUS PROVISIONS

11.1 LEGAL OBLIGATIONS, RELATIONS AND RESPONSIBILITIES

11.1.1 Laws to be Observed

11.1.2 Regulations

11.2 INDEPENDENT CONTRACTOR

11.3 EQUAL OPPORTUNITY

11.4 COMPLIANCE WITH THE IMMIGRATION REFORM AND CONTROL ACT OF 1986

11.5 ASSURANCE OF CONVICTION OF NON-BRIBERY

11.6 CONFLICT OF INTEREST

11.7 ASSIGNMENT AND SUBCONTRACTING

11.8 CONTINGENT FEES

11.9 MARYLAND PUBLIC INFORMATION ACT

11.10 TESTING AND INSPECTION

11.11 NO WAIVER OF RIGHTS – COLLEGE'S REMEDIES CUMULATIVE – COLLEGE'S DAMAGES

12. TERMINATION OF THE CONTRACT

12.1. TERMINATION FOR DEFAULT

12.2. TERMINATION FOR CONVENIENCE

ARTICLE 1 – GENERAL PROVISIONS**1.1. DEFINITIONS**

1.1.1. The "Agreement" is the written contract between the College and the Contractor.

1.1.2. The "College" is Montgomery Community College or Montgomery College Foundation, Inc.

1.1.3. The "Contractor" is the person or organization having a direct contractual relationship with the College for the execution of the Work under the Contract Documents.

1.1.4. The "Contract Documents" are the Agreement, the Request for Bid, Instructions for Bidders, the General Conditions of the Contract, Supplementary General Conditions, Preliminary Project Schedule, Drawings, Specifications, Addenda issued prior to execution of the Contract, Modifications issued after execution of the Contract, the Performance Bond, the Labor and Material Payment Bond, the Contractor's Bid Form and all attachments thereto received from the Contractor. The term "Contract" when used in the Specifications or Drawings shall be considered as synonymous with the term "Contract Documents".

1.1.5. The "Specifications" are the portion of the Contract Documents included in the Project Manual consisting of the written requirements for materials, equipment, construction systems, standards and workmanship for the Work, and performance of related services.

1.1.6. The "Drawings" are those enumerated in the Specifications and those incorporated in the Contract Documents as the work progresses.

1.1.7. The "Project Manual" is the volume that includes the Specifications as well as Bidding Requirements, Contract Form, and General Conditions

1.1.8. The term "Work" means all of the obligations undertaken by the Contractor pursuant to the Contract Documents. Work includes, unless specifically excepted, the furnishing of all material, labor, equipment, supplies, plant, tools, scaffolding, transportation, supervision, insurance, taxes and all other services, facilities and expenses necessary for the full performance and completion of the requirements of the Contract Documents. "Work" also means that which is produced, constructed, or built pursuant to the Contract Documents.

1.1.9. The term "Project" is the total construction of which the Work performed under the Contract Documents may be the whole or a part and which may include construction by the College or by separate contractors.

1.1.10. The term "Subcontractor" means any individual, partnership, firm, corporation or business entity other than an employee of the Contractor, who has a contract with the Contractor to furnish labor, or labor and materials for the Work. The term also includes Subcontractors of a Subcontractor. The term does not include vendors who furnish materials not worked to a special design according to the Drawings and Specifications.

1.1.11. The term "Site" or "Premises" means the area or areas indicated and such additional areas or locations upon which or in which Work under this Contract is being performed together with such areas adjacent thereto, as may be designated for the Contractor's use for a specified, limited period of time by the College.

1.1.12. The "Architect/Engineer" is the person commissioned by the College to design the Work and/or provide construction-phase architectural or engineering services. If the design was performed by the College, "Architect/Engineer" shall refer to the College.

1.1.13. The term "Contract Time" or "Time" and "Completion Date" is the number of calendar days

(including weekends and holidays) shown in the Contract Documents as the time allowed for completion of the Work. If a calendar date of completion is shown in the Contract Documents in lieu of the number of calendar days, the Work shall be completed on or before that date.

1.1.14. The term "Contract Sum" refers to the total sum, including authorized adjustments, allotted in the Contract Documents for the services performed by the Contractor for satisfactory completion of all of the Work required by the Contract Documents.

1.1.15. "Shop Drawings" are drawings, diagrams, schedules and other data specially prepared for the Work by the Contractor or a Subcontractor, manufacturer, supplier or distributor to illustrate some portion of the Work.

1.1.16. "Product Data" are illustrations, standard schedules, performance charts, instructions, brochures, diagrams and other information furnished by the Contractor or a Subcontractor, manufacturer, supplier or distributor to illustrate materials or equipment for some portion of the Work.

1.1.17. "Samples" are natural materials, fabricated items, equipment, devices, appliances or parts thereof as called for in the Specifications, and any other samples as may be required by the College to determine whether the kind, quality, construction, workmanship, finish, color and other characteristics of the materials, etc., proposed by the Contractor conform to the requirements of the Contract Documents. Samples shall establish the kind, quality and other required characteristics of the various parts of the Work, and all Work shall be in accordance with the accepted samples.

1.1.18. The term "Request for Information" refers to a written instrument submitted by the Contractor requesting that a clarification with respect to the Contract Documents be provided by the Architect/Engineer.

1.1.19. The term "Change Order" refers to a written instrument signed by the College which describes a directive by the College which is a change in the Work.

1.1.20. The "College's Representative" is the Chief Facilities Officer or designee.

1.1.21. The "College's Representative and/or Construction Manager" is(are) the person(s) or entity(ies) retained by the College to provide project and construction management services, including administration of the Contract. The College may exercise any power or authority of the College's Representative and/or Construction Manager under the Contract.

1.1.22. "Day" means a calendar day unless otherwise designated.

1.1.23. "Notice to Proceed" means a written notice to the Contractor of the date on which it shall begin the prosecution of the Work. The Contract Time shall begin to run from the starting date established in the Notice to Proceed.

1.1.24. "Written Notice" means giving of notice under the Contract by one party to the other. Unless otherwise indicated in the Contract Documents, Written Notice shall be deemed to have been duly served on the Contractor if delivered in person to the individual or to the member of the firm or to an office of the corporation to whom it is directed, or if delivered by regular or certified mail to the last business address known to the College. Written Notice shall be deemed to have been given to the College upon actual receipt of Written Notice by the College.

1.2. CONTRACT DOCUMENTS

1.2.1. Correlation and Intent of Contract Documents

1.2.1.1. The Contract Documents are complementary, and what is required by any one shall be

as binding as if required by all. Their intent is to include in the scope of the Contract, at no additional cost to the College, all Work necessary for proper completion of the Work ready for continual efficient operation that is reasonably inferable from the Documents.

1.2.1.2. Prior to bidding, the Contractor shall obtain from the College's Representative and/or Construction Manager clarification of all questions which may have arisen as to the intent of the Contract Documents, or any conflict between two or more items in the Contract Documents. Should the Contractor fail to obtain clarification, then the College may direct that the Work proceed by any method indicated, specified or required by the Contract Documents, in the judgment of the College. The direction by the College shall not constitute the basis for a claim for extra costs by the Contractor. The Contractor acknowledges that it had the opportunity to request clarification prior to submitting its bid to the College and that it is not entitled to claim extra costs as a result of failure to request such clarification.

1.2.1.3. The College's Representative and/or Construction Manager shall make recommendations regarding the amount, quality, acceptability and fitness of the several kinds of Work and materials which are to be paid for under this Contract and shall make recommendations regarding all questions which may arise in relation to the Work and the construction thereof. The College's decision, based on the College's Representative and/or Construction Manager's recommendation, shall be final and conclusive, except as herein otherwise expressly provided. In case any question shall arise between the parties relative to the Contract Documents, the determination or decision of the College shall be a condition precedent to the right of the Contractor to receive payment for the Work under the Contract related to such questions.

1.2.1.4. In the event of conflicts or discrepancies among the Contract Documents, interpretations will be based on the more restrictive condition or in consideration of following priorities:

- (1) Any modifications to the Contract Documents executed after the date of the Contract, with the Modifications having the latest date having the greatest authority.
- (2) The Contract.
- (3) The General Conditions.
- (4) Drawings and Specifications.

In the event of a conflict or discrepancy within the Specifications or the Drawings, or between the Drawings and the Specifications, the better quality or greater quantity of Work shall be provided in accordance with the College's interpretation.

1.2.1.5. The College's Representative and/or Construction Manager and Architect/Engineer shall make recommendations to the College to clarify the meaning and intent of the Specifications and the Drawings where the same may be found unclear or be in dispute.

1.2.1.6. The Contractor is responsible for coordinating and completing the various parts of the Work. No part of the Work shall be left in an unfinished or incomplete condition because of a disagreement between the Contractor and Subcontractors, or between Subcontractors and the Contractor as to where the Work of one begins and ends in relation to the Work of the other. Any adjustments due to differences or conflicts which may arise between the Work of the Contractor under this Contract and the work of other contractors performing work for the College shall be determined by the College and the College's Representative and/or Construction Manager.

1.2.1.7. Generally, the Specifications describe Work which cannot be readily indicated on the Drawings and indicate types, qualities and methods of installation of the various materials and equipment required for the Work. The Specifications are not intended to mention every item of Work which can be adequately shown on the Drawings. The Drawings are not intended to show all items of Work described or required by the Specifications even if they are of such nature that they could have been shown thereon. All materials or labor for Work which are shown on the Drawings, or are reasonably inferable there from as being necessary to produce a finished work,

shall be provided by the Contractor whether or not the Work is also expressly covered in the Specifications

1.2.2. Specification Format

1.2.2.1. The Specifications are separated into titled sections for convenience only and not to identify the trade or craft required to perform the Work. The titled section shall not operate to make the College an arbitrator for the division of responsibility between Contractor and its Subcontractors, and between its Subcontractors, nor shall such sections relieve the Contractor from the responsibility for the satisfactory completion of the entire Work regardless of the division.

1.2.2.2. The General Conditions are a part of each and every section of the Specifications.

1.2.2.3. The Specifications may be abbreviated and include incomplete sentences. Omissions of words or phrases such as "the Contractor shall", "shall be", etc., are intentional; nevertheless, the requirements of the Specifications are mandatory. Omitted words or phrases shall be supplied by inference in the same manner, as they are when a "note" occurs on the Drawings.

1.2.2.4. Words in the singular shall include the plural whenever applicable, or the context so indicates.

1.2.2.5. Where "as shown", "as indicated", "as detailed" or words of similar import are used, reference is made to the Drawings accompanying the Specifications unless otherwise stated. Where "as directed", "as required", "as permitted", "as authorized", "as approved", "as accepted", "as selected", or words of similar import are used, the direction, requirement, permission, authorization, approval, acceptance or selection by the College is intended unless otherwise stated. As used herein, "provide" means "provided complete in place", that is, furnished and installed and ready for operation and/or use.

1.2.3. Standard Specifications

1.2.3.1. Any reference to standard specifications of any society, institute, association or governmental authority is a reference to the standard specifications of such organization and to their methods of installation of the various materials and equipment required for the Work which are in effect at the time bids are due. It is not intended to mention every item of work described or required by the standard specifications even if they are of such nature that they could have been shown thereon. All materials or labor for work which are inferable there from, as the Contractor shall provide being necessary to produce a finished job at the date of the Contractor's bid. If such specifications are revised prior to completion of any part of the work to which such revision would pertain, the Contractor may, if acceptable to the College, perform such work in accordance with the revised specifications.

1.2.3.2. The standard specifications, except as modified in the Specifications for the Project, shall have full force and effect as though printed in the Specifications.

1.2.4. Ownership

1.2.4.1. The Drawings, Specifications and other documents prepared by the Architect/Engineer, are owned by the College. Copies thereof furnished to the Contractor, are for use solely with respect to this Project.

ARTICLE 2 – COLLEGE

2.1. AUTHORITY OF COLLEGE'S REPRESENTATIVE

2.1.1. The College's Representative has the authority to perform all of the College's and/or Construction Manager's functions and to accept, modify or reject College's and/or Construction Manager's decisions.

2.1.2. The College's Representative is NOT authorized to make determinations (as opposed to recommendations) that:

2.1.2.1. Alter or modify the Contract Documents;

2.1.2.2. Terminate or cancel the contracts.

2.2. RESPONSIBILITIES OF THE COLLEGE'S REPRESENTATIVE AND/OR CONSTRUCTION MANAGER

2.2.1. The College's Representative and/or Construction Manager shall be an agent of the College to the extent set forth in the Contract Documents. Any non-College employee in such role shall not be deemed to be the employee of the College for any purpose in connection therewith. The College's Representative and/or Construction Manager shall have full authority to act, or to cause others to act, on behalf of the College to assure that the Work is carried out in full compliance with the requirements of the Contract, and to otherwise generally protect the College's interests.

2.2.2. The College's Representative and/or Construction Manager will determine in general that the Work of the Contractor is being performed in accordance with the Contract Documents, and will use his best efforts to guard the College against defects and deficiencies in the Work of the Contractor.

2.2.3. The College's Representative and/or Construction Manager shall provide administrative management and related services as required to coordinate the Work of the Contractor and separate contractors with each other and with the activities of the Architect/Engineer to complete the Project in accordance with the College's objectives for cost, time and quality.

2.3. RESPONSIBILITIES OF THE ARCHITECT/ENGINEER

2.3.1. Architect/Engineer's Status

2.3.1.1. The College may maintain staff personnel from the Office of Central Facilities, or as separate architectural and/or engineering services retained by the College, at the site of the Work for field observation and day-to-day monitoring of the Work.

2.3.1.2. The Architect/Engineer shall assist the College during the construction period and with the College's Representative and/or Construction Manager shall observe the Work in process on behalf of the College. The Architect/Engineer will not be responsible for construction means, methods, techniques, sequences or procedures or for safety precautions and programs in connection with the Work. The Architect/Engineer shall have authority to act on behalf of the College only to the extent expressly provided in the Contract Documents or otherwise in writing.

2.3.1.3. With the College's Representative and/or Construction Manager, the Architect/Engineer may advise the College with respect to claims of the College or the Contractor, on matters relating to the execution and progress of the Work and on the interpretation of the Contract Documents.

2.3.1.4. Together with the College's Representative and/or Construction Manager, the Architect/Engineer shall certify applications for progress payments and final payment that the Contractor has complied with the requirements of the Contract Documents.

2.4. COLLEGE'S RIGHT TO STOP OR SUSPEND WORK

2.4.1. Stopping of the Work

2.4.1.1. The College's Representative and/or Construction Manager may stop all or part of the Contractor's Work, if in the opinion of the College's Representative and/or Construction Manager the Contractor has performed Work not in conformance with the Contract Documents. The Work may be stopped until such time that the defective conditions have been corrected. All costs related to the stoppage of the Work shall be borne by the Contractor.

2.4.2. Suspension of the Work

2.4.2.1. The College unilaterally may order the Contractor in writing to suspend, delay or interrupt all or any part of the Work for a period of time as it may determine to be appropriate.

2.4.2.2. If the performance of all or any part of the Work is for an unreasonable period of time suspended, delayed or interrupted by an act or omission of the College in the administration of the Contract, an adjustment shall be made for any increase in the cost of performance of the Contract (excluding profit) necessarily caused by an unreasonable suspension, delay or interruption and the Contract modified in writing accordingly. No adjustment shall be made under this subsection for any suspension, delay or interruption to the extent (1) that performance would have been so suspended, delayed or interrupted by any other cause, including the fault or negligence of the Contractor; or (2) for which an equitable adjustment is provided for or excluded under any other provision in this Contract.

ARTICLE 3 – CONTRACTOR

3.1. RESPONSIBILITIES OF THE CONTRACTOR

3.1.1. The Contractor shall furnish all labor, materials, equipment, tools, construction equipment, machinery, plant, supplies, utilities, telephone, transportation, supervision, temporary construction, permits, insurance, taxes, bonds, contributions and other facilities and services necessary for proper execution and completion of the Work, whether temporary or permanent and whether or not incorporated or to be incorporated in the Work, as described in the Contract Documents.

3.1.2. Montgomery County or City of Rockville Complex Structures processes may apply to the project. When applicable, Contractor shall fulfill any necessary obligations related to that process.

3.2. CONTRACTOR'S ADMINISTRATION AND SUPERVISION OF THE WORK

3.2.1. Staff

3.2.1.1. The Contractor shall furnish a competent, qualified and adequate staff as necessary to administer coordinate, supervise and superintend the Work; to organize the procurement of all materials and equipment so that they will be available at the time they are needed for the Work; and to keep an adequate force of skilled workers on the job to complete the Work in accordance with all requirements of the Contract Documents and to the entire satisfaction of the College's Representative and/or Construction Manager. Key members of the staff shall not be changed without the consent of the College's Representative and/or Construction Manager.

3.2.1.2. Prior to commencement of the Work, the Contractor shall select a project manager who will have full responsibility for the prosecution of the Work, with full authority to act in all matters as necessary for the proper coordination, direction and technical administration of the Work and who shall attend meetings at such place or places as determined by the College's Representative and/or Construction Manager in order to render reports on the progress of the Work.

3.2.2. Supervision

3.2.2.1. The Contractor shall efficiently supervise the Work, using its best skill and attention. It shall carefully study and compare all drawings, specifications and other instructions and shall at once report to the College's Representative and/or Construction Manager any error or omission which it may discover, and shall subsequently proceed with the Work in accordance with instructions from the College's Representative and/or Construction Manager concerning such error or omission.

3.2.2.2. The Contractor shall assign to the job throughout its duration a well-qualified, competent superintendent and any necessary assistants, all of whom must be satisfactory to the College's Representative and/or Construction Manager. The superintendent shall represent the Contractor in its absence and all directions given to him shall be as binding as if given to the Contractor. Important directions shall be confirmed in writing to the Contractor. Other directions shall be so confirmed on written request in each case.

3.2.2.3. The College's Representative and/or Construction Manager shall not supervise the Work. The means, methods, techniques, sequences, procedures and safety measures utilized in the performance of the Work are the sole responsibility of the Contractor, subject to overall coordination of the College's Representative and/or Construction Manager. Any means, method, techniques, sequences or procedures set forth in the Contract Documents are solely to specify the desired end product; and if the means, methods, techniques, sequences or procedures will not result in the desired end product or is unsafe or illegal because of some inherent defect in the Specifications or the particular conditions under which the Work is being performed, it is the Contractor's responsibility to select a correct means, method, technique, sequence or procedure. Nothing in the College's Representative and/or Construction Manager's review of the general quality and progress of the Work, including acceptance of submittals and Work, shall be construed as the assumption of authority or supervision over the performance of the Work.

3.2.3 Subcontracts

3.2.3.1. The Contractor shall, prior to the execution of the Contract, notify the College in writing of the names of Subcontractors, if any, proposed for the principal parts of the Work and for such other parts of the Work as the College's Representative and/or Construction Manager may direct. The Contractor shall not employ any Subcontractor that the College may, within a reasonable time, object to for any reason.

3.2.3.2. The Contractor is as fully responsible to the College for the acts and omissions of its Subcontractors and of persons either directly or indirectly employed by them, as it is for the acts and omissions of persons directly employed by it.

3.2.3.3. Nothing contained in the Contract Documents shall create any contractual obligation between any Subcontractor and the College.

3.2.3.4. The Contractor agrees to bind every Subcontractor, and every Subcontractor agrees to be bound by the terms of the Contract, the Drawings and the Specifications as far as applicable to its Work, including the following provisions, unless specifically noted to the contrary in a subcontract approved in writing as adequate by the College.

3.2.3.5. The Subcontractor agrees:

- (1) To be bound to the Contractor by the terms of the Contract, the Drawings and the Specifications, and to assume toward the Contractor all the obligations and responsibilities that it, by those documents, assumes toward the College.
- (2) To submit to the Contractor applications for payment in such reasonable time as to

enable the Contractor to apply for payment.

3.2.3.6. The Contractor agrees to place in its subcontracts with Subcontractors:

- (1) To be bound to the Subcontractor by all the obligations that the College assumes to the Contractor under the Contract, the Drawings and the Specifications, and by all the provisions thereof affording remedies and redress to the Contractor from the College.
- (2) To pay the Subcontractor, upon the payment of certificates, if listed in the Schedule of Values the amount allowed to the Contractor on account of the Subcontractor's Work to the extent of the Subcontractor's interest therein.
- (3) To make no demand for liquidated damages for delay in any sum in excess of such amount as may be specifically named in the subcontract.
- (4) That no claims for services rendered or materials furnished by the Contractor to the Subcontractor shall be valid unless written notice thereof is given by the Contractor to the Subcontractor during the first ten days of the calendar month following that in which the claim originated.
- (5) To give to the Subcontractor an opportunity to be present and to submit evidence in any decision involving its rights.

3.2.4. Behavior of Contractor's Employees, Agents and Subcontractors

3.2.4.1. The College is committed to providing a work and study environment that is free from discrimination and harassment on the basis of race, color, religious creed, ancestry, national origin, age, sex, marital status, handicap, pregnancy or status as a disabled veteran or veteran of the Vietnam Era. Behavior contrary to this philosophy, which has the purpose or effect of creating an intimidating, hostile, or offensive environment, will not be tolerated by the College, and it is the Contractor's responsibility to ensure that such behavior by its employees, agents and subcontractors does not occur.

3.2.4.2. This policy extends to maintaining an environment free from sexual harassment. Therefore, sexual advances, sexual remarks, requests for sexual favors, and other verbal or physical conduct of a sexual nature must not be condoned or permitted by the Contractor. This prohibition extends to such harassment within the employment context as well as harassment of students, staff and visitors of the College. It should be assumed that all sexual behaviors by the Contractor's employees, agents or subcontractors on any campus or facility of the College, whether owned, operated, maintained or leased by the College, is improper and unwelcome.

3.2.4.3. Montgomery College is a tobacco free institution. Use of tobacco products is prohibited in all indoor and outdoor College-owned facilities and facilities leased and controlled by the College as well as at meeting or conferences sponsored by the College. This use prohibition extends to Contractors' employees, agents, subcontractors and vendors.

3.3. MATERIALS, LABOR, EQUIPMENT AND PROCESSES

3.3.1. Proposals

3.3.1.1. Proposals shall be based upon the materials, equipment or processes specifically named, implied in or reasonably inferable from the Contract Documents.

3.3.1.2. In cases where work is to be performed in an existing building, proposals shall be based on Contractor's review of existing conditions by means including but not limited to: site inspection and review of existing College documentation, if any, including data from the Environmental Safety Office. Failure or omission of the Contractor to inspect the site and examine available documents shall in no way relieve the Contractor from obligations with respect to his bid, nor constitute grounds for a subsequent claim.

3.3.1.3. Certain project proposals shall be based on Prevailing Wage Rate schedule provided by and the reporting requirements of the State of Maryland's Department of Labor, Licensing and Regulation (DLLR). If guidance regarding applicability of Prevailing Wage Rates is not otherwise included in the Contract Documents, Contractor shall request a determination of applicability from the College prior to submitting a proposal.

3.3.2. Labor, Materials and Equipment

3.3.2.1. The Contractor shall enforce strict discipline and good order among the Contractor's employees and other persons carrying out the Contract.

3.3.2.2. The Contractor shall furnish sufficient forces to ensure the prosecution of the Work within the time stated in the Contract.

3.3.2.3. The Contractor shall comply with the provisions of Sections 17208 entitled Prevailing Wage Rates, when applicable, and 17301 through and including 17306 of the State Finance and Procurement Article of the Annotated Code of Maryland (as amended from time to time) entitled "Steel Procurement for Public Works."

3.3.2.4. Unless otherwise specified, all materials and equipment to be permanently installed in the Work shall be new, and shall be of such quality as required to satisfy the standards of the Contract Documents. The Contractor shall, if required, furnish satisfactory evidence as to kind and quality of all materials and equipment.

3.3.2.5. The Contractor shall not permit employment of unfit persons or persons not skilled in tasks assigned to them. All labor shall be performed by workers skilled in their respective trades, and work produced shall be of good quality so that first class work in accordance with the standards of construction set forth in the Contract Documents will result.

3.3.3. Or Equal

3.3.3.1. Where materials are specified by name, or several names, without the words 'or equal' following such name(s) the Contractor shall use and/or supply the named material that meets all the requirements of the Specifications.

3.3.3.2. Where the words 'or equal' are included, at the Contractor's sole risk, the Contractor may submit a material it considers to be equal in quality, capacity, size, or other determining criteria. The burden of submitting adequate information to the College to prove equality of materials shall be the responsibility of the Contractor. Whether an equal or specified product is proposed, all of the units of a given type required for and used in the Work must be the same in material and manufacture. The decision of the College with regard to quality of materials shall be final. The College may reject a proposed equal without cause and the Contractor shall not be entitled to additional compensation.

3.3.4. Substitutions

3.3.4.1. Should the Contractor desire to substitute another material for one or more specified by name, it shall apply in writing to the College's Representative and/or Construction Manager for permission and state the credit or extra, if any, involved with the use of such material.

3.3.4.2. Contractor shall endeavor to submit substitution requests for consideration prior to submitting a price proposal. Requests shall be accompanied by detail sufficient to facilitate the College's evaluation.

3.3.4.3. Any substitutions requested after the award of the Contract will be considered only under the following circumstances:

- (1) When the specified product is not available; or
- (2) When, if a certain product or process is specified and a guarantee of performance is required and, in the judgment of the Contractor, the specified product or process will not produce the desired results; or
- (3) When a substitution, in the opinion of the College is in its best interest.

3.3.4.4. Requests for substitutions of products, materials or processes other than those specified shall be accompanied by evidence that the proposed substitution: (1) is equal in quality and service-ability to the specified item; (2) will not entail changes in details and construction of related work; (3) will be acceptable in consideration of the required design and artistic effect; and (4) will provide a cost advantage to the College. The Contractor will furnish with his request such drawings, specifications, samples, performance data and other information as may be required of it to assist the College in determining whether the proposed substitution is acceptable. The burden of proof shall be upon the Contractor.

3.3.4.5. Regardless of the evidence submitted or any review or independent investigation by the College, a request for a substitution of products, materials or processes is a warranty by the Contractor to the College that (1) the requested substitution is equal in quality and serviceability to the specific item; (2) will not entail changes in details and construction of related work; (3) will be acceptable in consideration of the required design and artistic effect; (4) will not involve any additional cost to the College other than that specified in an accompanying request for a change order; and (5) the Contractor will provide the same or better warranty for the substitution that the Contractor would for that specified.

3.3.4.6. The College's acceptance of a substitution does not relieve the Contractor of responsibility for any unforeseen consequences and/or costs associated with the substitution.

3.3.4.7. The College may reject a proposed substitution without cause.

3.3.5. Required List of Materials and Equipment

3.3.5.1. Unless otherwise indicated in the Contract Documents, the Contractor shall submit to the College's Representative and/or Construction Manager a comprehensive list of the manufacturer's products proposed for this Work as soon as practicable and within thirty (30) calendar days after receipt of notice to proceed. The list shall include information on materials, equipment and fixtures as may be required for the College's Representative and/or Construction Manager's preliminary review; partial lists will not be considered. Acceptance of this list of products shall not be construed as a substitute for the shop drawings, manufacturer's descriptive data and samples which are required by the Contract Documents, but rather as a base from which more detailed submittals shall be developed for the College's final review.

3.4. WARRANTY/GUARANTEES

3.4.1. Except to the extent that the Contract Documents impose greater warranty obligations on the Contractor for all or any part of the Work, the Contractor warrants:

3.4.1.1. that the materials and equipment furnished under the Contract will be of good quality and new unless otherwise required or permitted by the Contract Documents;

3.4.1.2. that the Work contains no faulty or imperfect material or equipment or any imperfect, careless or unskilled workmanship;

3.4.1.3. that all mechanical and electrical equipment, machines, devices, etc., shall be adequate

for the use to which they are intended and shall operate with ordinary care and attention in a satisfactory and efficient manner; and

3.4.1.4. that the entire Work shall be watertight and leak proof in every particular.

3.4.1.5. Unless otherwise indicated in the Contract Documents, for a period of one year commencing on the date of Substantial Completion or such other date agreed upon, the Contractor shall re-execute, correct, repair, or remove and replace with proper Work, without cost to the College, any Work found not to be as guaranteed by this section or otherwise not in conformity with the Contract and that it will make good all damages or cost to other Work or materials in the process of complying with this section in accordance with Article 10, Correction of Work. The Contractor shall pay for tests and inspections made necessary by faulty Work. The correction period shall be extended with respect to portions of Work first performed after Substantial Completion by the period of time between Substantial Completion and the actual performance of the Work. This obligation shall survive Final Completion of the Work under the Contract and the Contract Close Out.

3.4.2. Nothing contained in Subsection 3.4.1.5 shall be construed to establish a period of limitation with respect to other obligations which the Contractor might have under the Contract Documents. Establishment of time period of one year as described in Subsection 3.4.1.5 relates only to the specific obligation of the Contractor to correct the Work and has no relationship to the time within which the obligation to comply with the Contract Documents may be sought to be enforced nor to the time within which proceedings may be commenced to establish the Contractor's liability with respect to the Contractor's obligations other than specifically to correct the Work.

3.4.3. The Contractor shall cause to be assigned to the College all warranties/guarantees furnished by manufacturers and suppliers of equipment and supplies for the Work. The assignment shall not affect Contractor's warranty obligations to the College.

3.5. TAXES

3.5.1. The College is not exempt from payment of Maryland State Sales Tax and Municipal Occupation (Sales) and/or Use Taxes on materials purchased for this Work.

3.5.2. The Contractor and Subcontractors shall pay sales, consumer, use, unemployment, old age pension and/or other taxes imposed by local, state and/or the Federal government, except taxes and assessments on the real property comprising the Work site. The Contractor is to include such expenses in its proposal.

3.6. PERMITS AND LICENSES

3.6.1. The College will file for the building permit, if one is necessary, with the local authority. The Contractor shall obtain and pay for any and all permits, other than the building permit, licenses and certificates of inspection necessary for the execution and completion of the Work as called for in the Contract Documents. The Contractor will be required to pay all necessary fees to local authorities for permits and inspections and it shall include the cost of the fees in its base bid. The College shall not be responsible for the actions or interpretations of county, municipal or other local agencies or officials with respect to the application of Federal, State or local laws, rules, ordinances, regulations, codes or policies to the Work.

3.6.2. The Contractor must be licensed as required by Title XVII, Subtitle VI or Title VIII of the Business Regulation Article, Annotated Code of Maryland.

3.7. PROSECUTION AND PROGRESS OF THE WORK

3.7.1. Notice to Proceed

3.7.1.1. After the Contract has been executed, the College's Representative and/or Construction Manager will issue to the Contractor a "Notice to Proceed" and this notice will stipulate the date on or before which the Contractor is expected to begin Work. The specified contract time shall begin on the starting date stated in the "Notice to Proceed." Any Work started or materials ordered before the starting date stated in the "Notice to Proceed" shall be at the risk of the Contractor. The Contractor is prohibited from doing any Work on the site until proof of the insurance required by the Contract is provided to the College.

3.7.2. Hours of Work

3.7.2.1. The Work shall be performed during regular working hours except in the event of emergency, or when required to complete the Work within the time stated in the Contract. What constitutes regular working hours will be agreed upon at the preconstruction conference.

3.7.2.2. The Work shall be suspended on the College's Commencement Day (typically the third Friday in May) unless otherwise agreed to by the College.

3.7.2.3. The Work may be performed on night shifts, overtime, Sundays and holidays when permission to do so has been obtained from the College, at no additional cost to the College, and provided that Contractor complies with any additional regulations regarding off-hours work mandated by regulatory authorities.

3.7.3. Construction Schedule

3.7.3.1. Time

- (1) All time limits in the Contract Document are of the essence of the Contract. Contractor and the College agree that the time stated in the Contract for the completion of the Work is a reasonable time, considering the usual climatic range and the usual business conditions prevailing in the locality of the project. The Contract time shall be the full time allowed or required for completion of every task involved in completion of the Work, including lead-time for ordering and fabrication of equipment and materials.
- (2) The College is not obligated (a) to accept an early completion schedule from the Contractor, or (b) to accept the project prior to the completion date stated in the Contract. The College will not be liable for any claims based on the Contractor's assertion of an intention to finish early.

3.7.3.2. Preliminary Schedule

- (1) The Contractor shall agree to comply with the Preliminary Project Schedule prepared by the College and/or Construction Manager and included in the Contract Documents or with the Contractor's Proposed Project Schedule, if one was required as part of the Contractor's proposal submission. Agreement by the Contractor to comply with the Preliminary Project Schedule or Contractor's Proposed Project Schedule also means agreement by the Contractor to comply with subsequent reasonable updates prepared or requested by the College and/or Construction Manager.
- (2) Within 14 days of the execution of the Contract, Contractor must submit for approval, preliminary schedule information outlining all activities for the Contractor's work as may be reasonably requested by the College's Representative and/or Construction Manager. Coordinate schedule information with milestones indicated in the Preliminary Project Schedule. This preliminary information must be approved prior to the first Application for Payment being processed. Include each significant

construction activity, coordinate each activity with other activities and schedule each construction activity in proper sequence. The College's Representative and/or Construction Manager may decline to issue a Notice to Proceed until Contractor has submitted the required schedule information and it is approved by the College's Representative and/or Construction Manager. Nothing in this section shall be construed to require the College's Representative and/or Construction Manager to issue a Notice to Proceed when the required schedule information has been submitted and approved.

- (3) With submission of the preliminary schedule information, include a listing by date of submission of all submittals required. Identify those required to maintain orderly progress of the Work, and those required early because of long lead time for manufacture or fabrication.

3.7.3.3. Completion Schedule

- (1) Within 30 days after Contract execution and at such other times as required by subsections 3.7.3.4 and 3.7.3.8, the Contractor shall submit for approval, updated schedule information indicating the time allocated by the Contractor for the performance of each portion of the Work and the submittal information required by subsection 3.7.3.2 (3), properly and reasonably sequenced for achieving each task shown on the schedule. Coordinate schedule with milestones indicated in the Preliminary Project Schedule.
- (2) The Contractor's construction schedule shall begin with the date of issuance of Notice to Proceed and conclude with the required date of final completion of the project as stated in the Contract Documents. Float or slack time available in the schedule at any time shall not be for the exclusive use or benefit of either the Contractor or the College, but is jointly owned.
- (3) The Contractor's schedule information shall include a complete itemized breakdown of the Work, listed by activity or event number, including items related to the General Conditions, all necessary dates for submittal, review and response, and re-submittal (if necessary), and for each activity shall show at a minimum: (1) a sequence of operations; (2) the dates of commencement and completion of each item of the Work; and (3) delivery for material and equipment. Unless otherwise indicated in the Contract Documents or agreed upon by the College's Representative and/or Construction Manager, the duration of each activity shall be twenty-one calendar days or less.
- (4) Contractor shall submit with each Application for Payment revised schedule information accurately updated to reflect all: (1) revisions to the schedule (2) changes made or planned in the construction sequence; (3) actual construction activities to date including (i) commencement and completion dates for activities started or completed during the reporting period; and (ii) current progress of activities started in prior reporting periods including completion dates for activities completed during the reporting period; (4) delays and their effects on the critical path; (5) extensions of time granted by the College and (6) the Contractor's planned schedule or recovery schedule for completing remaining activities. This required schedule information update shall be furnished monthly whether or not Contractor submits an application for payment in that month.
- (5) In the event that change orders are experienced, they shall be reflected as new activities, or as changes in logic and/or time framing of existing activities. They shall be introduced at the next updating after receipt of a change order, and shall be subject to the approval of the College's Representative and/or Construction Manager. Change order logic shall affect only those intermediate activities and performance dates directly concerned. Adjustments required in completion dates for those intermediate dates, or for the contract as a whole, will be considered only to the extent that there is not sufficient remaining float to absorb the additional time which may be authorized for completion of individual activities.

- (6) Whenever the project shall be behind schedule or alleged by either party to be behind schedule, the College may require the Contractor to furnish, at no additional cost to the College revised schedule information (hereinafter called a "recovery schedule") showing how the Contractor will finish their work by the Contract completion date.
- (7) All of Contractor's schedule information, including monthly schedule information updates and any recovery schedule information required shall be reviewed by the College's Representative and/or Construction Manager and shall be approved or disapproved by it.
- (8) The Contractor shall cooperate with the College's Representative and/or Construction Manager in scheduling and performing the Contractor's Work to avoid conflict, delay in or interference with the Work of other contractors or the construction or operation of College's own forces. The Contractor shall participate with other contractors and the College's Representative and/or Construction Manager and College in reviewing schedules when directed to do so. The Contractor shall make any revisions to their construction schedule information deemed necessary after a joint review.
- (9) Approval by the College's Representative and/or Construction Manager of any schedule information submitted shall constitute approval of the schedule information only for general conformity with Contract requirements and shall not constitute approval, acceptance or admission of the reasonableness, accuracy, achievability, or feasibility of the schedule information or of the Contractor's ability to meet the schedule, or waiver or excuse of default or delay by the Contractor, extension of the time for completion, waiver or modification of Contract requirements, admission of fault or responsibility for delay on the part of the College or acceptance or admission on the part of the College of any liability or responsibility for the schedule or for acceleration or other costs or delay damages of the Contractor which are inferable from the Contractor's schedule information or update.
- (10) The College is not obligated to pay the Contractor for Work completed until proper, accurate schedule information, and updates are furnished as required and it is not liable for and Contractor is not entitled to damages, compensation, or time extensions for delays starting, occurring or continuing during the period when an accurate and reasonable schedule information or update was due but not furnished by the Contractor.

3.7.3.4. All schedule information, including initial schedule information, recovery schedule information and monthly updates, shall be submitted in three (3) paper copies and one (1) electronic copy in Portable Document Format (PDF), unless otherwise indicated.

3.7.4. Progress Meetings

3.7.4.1. Contractor shall plan and participate in routine project progress meetings to brief College's Representative and/or Construction Manager and Architect/Engineer on the status of the project. Frequency of meetings shall be determined at a preconstruction conference, but shall typically occur not less than every two weeks. Primary agenda topics shall include reporting status of: Regulatory Approvals, Submittals, RFI's, Commissioning, Safety, Security and Housekeeping, Schedule, Contracts/Finance and Close-Out. Unless otherwise indicated in the Contract Documents, meeting minutes will be prepared by the College's Representative and/or Construction Manager.

3.7.4.2. Contractor shall provide reasonable advance notice to the College's Representative and/or Construction Manager and Architect/Engineer regarding scheduling of pre-construction and pre-installation conferences with subcontractors. At a minimum, Contractor should anticipate College's participation in conferences related to underground work, demolition work, primary structural work, all building enclosure work, MEP and telecommunications, AV and security systems work.

3.7.5. Progress Meeting Documentation and Reports

3.7.5.1. Contractor shall prepare, maintain, monitor and make available to the College, reasonable project progress documentation including, but not limited to:

1. Contractor's Daily Reports: listing weather conditions, trades on site, manpower, brief description of activities underway, quality control issues raised, commissioning activities underway and any safety or security issues encountered. Append Daily Reports from Subcontractors to the Contractor's Daily Report.
2. Minutes from Pre-Construction and Pre-Installation conferences.
3. Minutes from Contractor's Subcontractor and/or Foreman's meetings: including agenda topics, brief summary of issues discussed resolutions discussed and issues requiring attention.
4. Inspection reports provided by Independent Testing Agencies and/or Laboratories, when applicable.
5. Inspection reports provided by any authorities having jurisdiction on the project.

3.8. REFERENCE DOCUMENTS FOR THE WORK

3.8.1. Progress Documents

3.8.1.1 The Contractor shall keep one complete set of all Drawings, Specifications, construction progress schedule, and shop drawings at the job-site and in good order. As the Work progresses, the Contractor shall keep a complete and accurate record of all changes or deviations from the Contract Documents, indicating the Work as actually installed. All underground utility locations associated with the scope of work, or revealed during the conduct of the work, shall be recorded by the Contractor's surveyor and referenced to a campus benchmark provided by the College. All such changes shall be neatly and correctly shown on black line prints of the drawings affected, or in the Specifications, with appropriate supplementary notes. This record set of prints of Drawings, shop drawings and Specifications shall be kept at the job site for inspection by the College's Representative and/or Construction Manager and Architect/Engineer.

3.8.2. Record Documents

3.8.2.1. At the completion of the Work, the Contractor shall certify by endorsement thereof, that each of the revised prints of the Drawings and Specifications is complete and accurate. Prior to the Contractor's application for final payment, and as a condition to its approval by the College, the Contractor shall assemble its record drawings and specifications, review them for completeness and submit them to the College's Representative and/or Construction Manager. The Contractor shall provide suitable transfer cases and deliver the records therein, indexed and marked for each division of the Work.

3.8.2.2. No review or receipt of such records by the College's Representative and/or Construction Manager shall be a waiver of any deviation from the Contract Documents or the shop drawings or in any way relieve the Contractor from its responsibility to perform the Work in accordance with the Contract Documents and the shop drawings to the extent they are in accordance with the Contract Documents.

3.9. SHOP DRAWINGS, PRODUCT DATA AND SAMPLES

3.9.1. After checking and verifying all field measurements and after complying with applicable procedures specified in the Contract Documents, Contractor shall submit to the College's Representative and/or

Construction Manager and Architect/Engineer, in accordance with the Contractor's schedule, shop drawings and other submittals which will bear a stamp or specific written indication that the Contractor has satisfied its responsibility under the Contract Documents with respect to the review of such submissions. The data on the shop drawing or submittal must be complete with respect to quantities, dimensions, specified performance and/or design criteria, materials and similar data to enable the Architect/Engineer to review the information as required. These documents shall be prepared in conformity with the best practice and standards for the trade concerned. Due regard shall be given to speed and economy of fabrication and erection.

3.9.2. Obtaining electronic documentation to aid in the preparation of shop drawing submittals shall be the sole responsibility of the Contractor and may be subject to certain terms and conditions required by the Architect/Engineer and/or College. The College cannot guarantee that electronic documentation prepared by the Architect/Engineer will be made available to the Contractor. If provided, Contractor shall not be entitled to rely on such documentation for accuracy and use of such documentation shall not in any way relieve the Contractor from its responsibility to perform the Work in accordance with the Contract Documents.

3.9.3. The Contractor shall prepare and routinely update a submittal log indicating the status of submittals.

3.9.4. Unless otherwise indicated in the Contract Documents or agreed to by the College in writing, the Contractor shall send the College one copy of all shop drawings and product data coincident with the initial and any subsequent submissions to the Architect/Engineer. The College will forward any comments it desires to make to the Architect/Engineer within the designated review time.

3.9.5. In addition to the items noted in the Specifications as requiring shop drawings or other details, shop drawings and details shall be required for all items which are specifically fabricated for the Work or when the assembly of several items is required for a working unit.

3.9.6. The College's Representative and/or Construction Manager and Architect/Engineer will examine the shop drawings and product data submittals with reasonable promptness. The College's Representative and/or Construction Manager and Architect/Engineer will note whether they are approved, approved with corrections and/or conditions, or rejected. The Architect/Engineer will return the shop drawings and project data submittals with the final action to the Contractor and also provide one copy each to the College and College's Representative and/or Construction Manager.

3.9.7. The Contractor must allow the Architect/Engineer, College's Representative and/or Construction Manager at least fourteen calendar days following receipt of each submittal or re-submittal of shop drawings and product data submittals to review the documents and respond to the Contractor. Items requiring longer than fourteen calendar days of review time will be identified in the Specifications. The minimum time allowed for the Architect/Engineer, College's Representative and/or Construction Manager to review the submittal shall be increased to the extent that additional time for review is needed due to the fault or the responsibility of the Contractor or its Subcontractors and suppliers. The Contractor will be notified of the cause of the delay and advised of how long it will take to complete the review; provided, however, that mere failure to give the Contractor such notice shall not entitle the Contractor to compensation or a time extension.

3.9.8. When the Architect/Engineer, College's Representative and/or Construction Manager or the College desires corrections, or rejects the drawings, the Contractor shall resubmit the drawings with the required corrections in a timely manner.

3.9.9. Unless the Contractor has, in writing, at the time of the submissions, expressly notified the Architect/Engineer, College's Representative and/or Construction Manager and the College to the contrary, the College and the Architect/Engineer may assume that shop drawings and other submittals from the Contractor are in conformity with the Contract Documents and do not involve any change in the

Contract price, or any change which will alter the space within the structure, or alter the nature of the building or Work from that contemplated by the Contract Documents, or constitute a substitution of material or equipment or a change in the Contract or the scope of Work. If the Contractor fails to give notice strictly in accordance with this subsection, approval of any shop drawing or submittal shall not be binding on the College.

3.9.10. The Contractor shall perform no portion of the Work requiring submittal and review of shop drawings, product data, samples and similar submittals until the respective submittal has been approved by the Architect/Engineer. Such Work shall be in accordance with accepted submittals. Work performed without approval shall be at the Contractor's risk.

3.9.11. Shop drawings, product data, samples and similar submittals shall be marked, tagged, or otherwise properly identified with the name of the Contractor, the name of the project, the purpose for which the samples are submitted, and the date and shall be accompanied by a letter of transmittal containing similar information, together with the Specification section number for identification of each item. Each tag or sticker shall have clear space for the stamps of the Contractor, College's Representative and/or Construction Manager and the Architect/Engineer.

3.9.12. Samples of materials which are generally furnished in containers bearing the manufacturers' descriptive labels and printed application instructions shall, if not submitted in the standard containers, be supplied with such labels and application standards.

3.9.13. Should the Contractor consider any rejection or notation on the shop drawings or other submittals by the College's Representative and/or Construction Manager or Architect/Engineer or any other action or inaction of the College's Representative and/or Construction Manager or the Architect/Engineer to cause an increase or decrease in the scope of the Work from that required by the Contract Documents, then the Contractor shall desist from further action relative to the item in question and shall in writing (1) immediately notify the Architect/Engineer, the College and College's Representative and/or Construction Manager; and (2) furnish them, within seven (7) days, with a notice explaining the nature of the change and whether increased or decreased cost and/or time is anticipated. No Work shall be executed until the entire matter is clarified and the Contractor is ordered by the College to proceed. Failure of the Contractor to serve written notice as required above, shall constitute a waiver of any claim in relation thereto.

3.10. SITE INFORMATION, ACCESS, USE AND RESTRICTIONS

3.10.1. Site Information

3.10.1.1. Contractor shall review existing conditions and related College record information to become completely familiar with site and adjacent conditions. Contractor shall make arrangements to review available documentation and explanatory site visits with College's Representative and/or Construction Manager and Campus Facilities Office.

3.10.2. Campus Coordination Requirements

3.10.2.1. Contractor shall furnish a Site Mobilization Plan to the College's Representative and/or Construction Manager for review and approval prior to the start of Work. Plan shall indicate features including proposed Construction Delivery route, Materials and Trash Storage Areas, Site Office and Toilet Facility locations, Fencing, Erosion Control Measures, Tree and Plant Protection, Temporary Lighting, Temporary Traffic Control Measures and Signage.

3.10.2.2. Contractor shall meet with Campus Facilities and Security Offices prior to the start of Work to review Contractor's proposed Site Mobilization Plan, and to coordinate project needs with Campus Operations and Maintenance, House and Grounds-keeping and Security operations.

3.10.2.3. In the event that Contractor's operations affect or disrupt campus access roads and/or building entrances or exits, Contractor shall coordinate maintaining or re-directing access in accordance with the contract documents and following the direction and policies of the Campus Security Office and any affected emergency service providers.

3.10.2.4. Contractor shall meet with College's Environmental Safety Office prior to the start of Work for projects where Hazardous Materials Abatement or use of Hazardous or Toxic Substances is expected.

3.10.2.5. Any Utility shut down required must be scheduled with relevant utility Owner and Campus Facilities at least 5 days in advance.

3.10.2.6. Unless otherwise indicated in the Contract Documents, vehicular and pedestrian access to properties shall be maintained as far as reasonably possible. Driveways to private properties shall not be blocked. Sidewalks and crossings shall be kept open for the passage of pedestrians. Streets shall not be unnecessarily obstructed and, unless the College shall authorize the complete closing of a street, the Contractor shall take such measures as may be necessary to keep the street open for traffic. The Contractor shall provide and maintain suitable and sufficient provisions, including but not limited to flag persons, barricades, warning signs and detour signs, necessary for the protection of the work and safety of the public. All barricades, obstructions and signage shall be illuminated from sunset to sunrise, daily.

3.10.2.7. Parking at all campus locations is limited. Other than one or two spaces for supervisory personnel, parking space for construction site personnel in campus parking lots should not be anticipated. For projects where work is confined within a site construction fence, Contractor may provide limited parking for construction personnel within that fenced area as long as parking does not impede progress of the work or impede access by emergency or campus service vehicles.

3.10.2. Coordination where Work is in or adjacent to an Occupied Existing Building

3.10.2.1. In cases where Work is scheduled to take place in or adjacent to occupied existing buildings, Contractor shall coordinate the Work as reasonably directed by the College's Representative and/or Construction Manager to reduce impact of construction operations on building occupants.

3.10.2.2. Noise that disrupts classes cannot generally be tolerated. The Contractor shall notify the College's Representative and/or Construction Manager before starting any work which might disrupt classes. Notification shall be given well in advance of any such situation in order that the Contractor and College's Representative and/or Construction Manager together can reach a mutually agreeable time in which the work can be accomplished. Noise of a brief/infrequent nature may not be found necessary to reschedule. Always contact the College's Representative and/or Construction Manager if in doubt. Any rescheduling required due to noise aversion will not be a cause for either a delay or cost claim.

3.10.3. Temporary Facilities

Unless otherwise indicated in the Contract Documents:

3.10.3.1. The Contractor shall be responsible for arranging with the College's Representative and/or Construction Manager for general services and temporary facilities as required for the proper and expeditious prosecution of the Work; including but not limited to: use of toilets; temporary storage; temporary electrical power; and temporary water.

3.10.3.2. The Contractor shall, at its own expense, make all temporary connections to utilities and services in locations acceptable to the College's Representative and/or Construction Manager

and local authorities having jurisdiction thereof; furnish all necessary labor and materials, and make all installations in a manner subject to the acceptance of such authorities and the College's Representative and/or Construction Manager; separately meter and pay for utilities (electricity, water, sewer, and telephone) consumed; maintain such connections; remove the temporary installation and connections when no longer required; restore the services and sources of supply to proper operating conditions.

3.10.3.3. The Contractor shall supply and maintain an office trailer or shed and a telephone, telefax and/or computer on the site for the purpose of facilitating construction coordination and communication.

3.10.3.4. At the completion of the Work, Contractor's onsite facilities shall be removed, and site restored to conditions that meet or exceed those existing at the start of Work.

3.10.4. Existing Utilities

3.10.4.1. The attention of the Contractor is directed to the likely presence of existing underground utilities and overhead utilities and poles located within the work site. The Contractor is cautioned that some utilities may not be catalogued on College or utility service provider record documents. Due to depth and/or types of materials used, some utilities may not be identifiable using traditional utility service locating methods.

3.10.4.2. Where any underground services are expected to be encountered during construction, prior to the start of work, the Contractor shall:

- (1) Review College record documents pertaining to affected underground services.
- (2) Interview Campus Facilities office with regard to affected underground services.
- (3) Call "Miss Utility" at least 48 hours in advance of construction for marking of public utilities.
- (4) Be responsible for costs and coordination of utility locator services necessary to locate and mark any private utility services within the work site.
- (5) Notify the College's Representative and/or Construction Manager, Campus Facilities office, electric utility company, natural gas supplier, providers of communications, and any affected utility or other organization with a right-of way in or immediately adjacent to the work area at least one week prior to starting work in the areas in which services are located and cooperate with any organization who elects to have a representative present during the conduct of the work.

3.10.4.3. The Contractor shall exercise special care not to damage or disturb the utility infrastructure in any way.

3.10.4.4. The Contractor shall carefully hand dig representative test pits across the full width of anticipated trenches to confirm utility locations and to reveal any unknown utility conditions prior to permitting use of mechanical excavation equipment.

3.10.4.5. All underground utility locations associated with the scope of work, or revealed during the conduct of the work, shall be recorded by the Contractor's surveyor and referenced to a campus benchmark provided by the College. Locations shall be recorded on project progress documents.

3.10.4.6. Contractor shall maintain utility paint marks and flags, showing utility location and depth, until work is complete and survey information is transferred to project progress documents.

3.10.4.7. Contractor shall notify the College's Representative and/or Construction Manager and Campus Facilities Office when underground utilities are discovered that are not identified by prevailing industry standards marking methods (eg. color-coded tape and trace wires for non-

metallic utilities). Campus Facilities office will coordinate proper marking of utilities prior to Contractor's completion of the work.

3.10.4.8. In the event that utility service is damaged during the conduct of the work, Contractor shall notify the College's Representative and/or Construction Manager and Campus Facilities and Security Offices. Repair of damages resulting from Contractor's actions shall be the responsibility of the Contractor. Regardless of responsibility, Contractor shall immediately undertake necessary repairs, including conducting work off-hours and/or on weekends, to ensure prompt restoration of service in order to minimize impact on College operations.

3.10.5. Erosion Control

3.10.5.1. The Contractor shall incorporate all permanent erosion control features, where applicable, into the Work at the earliest practicable time and shall maintain them in proper condition during the course of the Contract.

3.10.5.2. Temporary measures shall be used to control conditions that develop prior to installation of permanent control features, or that are needed to temporarily control erosion resulting from normal construction practices. Temporary controls may include off site control measures where such Work is necessary as a direct result of Contractor's construction activity.

3.10.6. Tree and Plant Protection

3.10.6.1. Unless otherwise shown in the Contract Documents, the Contractor shall protect all trees and plants which are liable to injury by construction operations and/or site mobilization plan.

3.10.6.2. Trees may not be used for any attachment or anchorage. Tree root zones shall be protected from overburden from construction traffic or storage of materials.

3.10.7. Snow and Ice Removal

3.10.7.1. Contractor shall provide snow and ice removal from within the project site area and from pedestrian or vehicular routes providing immediate access to or routing around the project site.

3.10.7.2. When the College is officially closed due to snow and ice conditions and the Contractor plans to work, it is the Contractor's responsibility to provide additional snow and ice removal, including removal beyond the site project limits, as necessary to provide access required by its Workers, Subcontractors and/or suppliers.

3.10.7.3. At all times, Contractor shall cooperate and coordinate his snow and ice removal activities with College's snow and ice removal activities.

3.10.8. Trash Removal: Salvage and Recycling

Unless otherwise indicated in the Contract Documents:

3.10.8.1. Salvage rights belong to the Contractor when the project scope of work includes demolition and removal of existing materials or equipment.

3.10.8.2. Contractor shall implement recycling practices as part of its trash removal protocol, with particular attention to sorting and recycling corrugated cardboard packaging materials, wood pallets, paper products and metal products.

3.10.9. Project Signage

3.10.9.1. Contractor may place his identification signage for promotional purposes at the Project site, subject to review and approval by College's Representative and/or Construction Manager.

3.11 HAZARDOUS AND TOXIC SUBSTANCES

3.11.1. Hazardous and Toxic Substances

3.11.1.1. The Contractor shall comply with all applicable federal, state, bi-county and local laws, ordinances and regulations relating to hazardous and toxic substances, including such laws, ordinances and regulations pertaining to access to information about hazardous and toxic substances, in effect on the date of the Contract and as amended from time to time. The Contractor shall further comply with any special provisions or requirements, including more stringent provisions, mandated by any entity having jurisdiction, including but not limited to the Montgomery County Department of Environmental Protection.

3.11.1.2. At least ten (10) calendar days prior to commencing any on-site Work required by these Contract Documents, the Contractor shall compile, maintain and submit to the College's Representative and/or Construction Manager a "Chemical Information List" which shall contain the following information for each hazardous and toxic substance used, manufactured, processed, formulated, packaged, repackaged, handled, reacted, transferred, or stored at the job site: the common name, the chemical name, and identification of the Work area in which the hazardous chemical is found. A copy of this list shall be posted at all times at the Contractor's on-site project office. This list shall be updated and maintained in a current status by the Contractor as to the hazardous and toxic substance used, manufactured, processed, formulated, packaged, repackaged, handled, reacted, transferred or stored at the job site. The Contractor shall submit to the College's Representative and/or Construction Manager an updated Chemical Information List at least 48-hours prior to the introduction of any additional hazardous and toxic substance not listed on the current Chemical Information List which is to be used, manufactured, processed, formulated, packaged, repackaged, handled, reacted, transferred or stored at the job site.

3.11.1.3. The Contractor shall provide the College's Representative and/or Construction Manager at least 48-hours prior to commencing Work requiring the use of a hazardous and toxic substance with a "Material Safety Data Sheet" or, in the case of a controlled hazardous waste substance, a hazardous waste manifest, for each hazardous and toxic substance listed or subsequently added to the Chemical Information List in compliance with applicable laws, ordinances and regulations.

3.11.2. Asbestos-Containing Materials

3.11.2.1. The Contractor shall not use, install or apply any asbestos-containing building materials on any Work. Any exception to this requirement must be requested in writing by the Contractor with an explanation of Work requirements. The College will review any such request and must approve in writing the use of any asbestos-containing building materials on any Work prior to use, installation or application. Upon completion of the project and before final acceptance is issued by the College, the Contractor shall provide the College's Representative and/or Construction Manager with written and notarized certification that it did not use, install or apply asbestos-containing materials.

3.11.3. Environmental Litigation

3.11.3.1. If the performance of all or any part of the Work is suspended, delayed or interrupted due to an order of a court of competent jurisdiction as a result of environmental litigation as defined below, or by the order of any state or federal agency or official enforcing applicable laws,

such expense, delay or interruption shall be considered as if ordered by the College under Article 2, College's Right To Stop Or Suspend Work. If it is determined that the suspension, delay, or interruption is due wholly or in part to acts or omissions of the Contractor or breach or violation of the terms of this Contract or acts of the Contractor not required by this Contract, the Contractor shall be responsible for all additional costs and delays resulting from such acts or omissions. The term "environmental litigation" as used herein means a complaint filed in court alleging that the Work will have an adverse effect on the environment and that the College has not duly considered, either substantively or procedurally, the effect of the Work on the environment.

3.12. CUTTING AND PATCHING

3.12.1. The Contractor shall be responsible for cutting, fitting or patching required to complete the Work or to make its parts fit together properly.

3.12.2. The Contractor shall not damage or endanger a portion of the Work or other construction of the College or separate contractors by cutting, patching or otherwise altering such construction, or by excavation. The Contractor shall not cut or otherwise alter such construction by the College or a separate contractor except with written consent of the College and of such separate contractor; such consent shall not unreasonably withhold. The Contractor shall not unreasonably withhold from the College or a separate contractor the Contractor's consent to cutting or otherwise altering its Work.

3.13. CLEANING

3.13.1. Progress Cleaning

3.13.1.1. The Contractor shall keep the premises and surrounding area free from accumulation of waste materials or rubbish caused by operations under the Contract, and shall remove and dispose of waste materials or rubbish prior to the end of each working day.

3.13.1.2. If the Contractor fails to clean up as provided in the Contract Documents, the College's Representative and/or Construction Manager may do so and the cost thereof shall be charged to the Contractor.

3.13.2. Final Cleaning

3.13.2.1. At completion of the Work the Contractor shall remove from and about the Work waste materials, rubbish, the Contractor's tools, construction equipment, machinery and surplus materials.

3.13.2.2. Contractor shall wet clean all floors and surfaces or otherwise clean any equipment and materials installed in accordance with manufacturer's instructions.

3.14. ROYALTIES, PATENTS AND LICENSE FEES

3.14.1. The Contractor assumes the risk that any materials, equipment, processes or other items required under the Contract or furnished by the Contractor are subject to any patent, copyright, mark, secret or other property right of another. The Contractor shall pay for all royalties and license fees and shall obtain all necessary licenses or permits to permit use of any such item by the College. Contractor shall defend all suits or claims of infringement of any patent, copyright, mark, secret or other property right of another and shall save the College harmless from loss or expense on account thereof.

3.14.2. When an item specified by the College or furnished by the Contractor infringes or is alleged to infringe any patent, copyright, mark, secret or other property right of another, the Contractor will, at its option, and at no additional cost to the College, (1) procure for the College the right to use the item; (2) replace the item with an approved, non-infringing equal; or (3) modify the item so that it becomes non-

infringing and performs substantially the same as the original item.

3.14.3. The review by the College of any method of construction, invention, appliance, process, article, device or material of any kind shall be for its adequacy for the Work, and shall not be an approval of the use thereof by the Contractor in violation of any patent or other rights or any third person.

3.15. INDEMNIFICATION

3.15.1 The Contractor shall be responsible for any property damage, loss, personal injury, death and/or any other damage which may occur by reason of the Contractor's acts, negligence, willfulness or failure to perform any of the obligations required by this Agreement. The Contractor agrees to indemnify and save harmless the College and its respective employees, volunteers, students, and trustees, as applicable, (the "Indemnitees") from any claims, loss, costs, damages or other expenses suffered or incurred by the Indemnitees, including attorneys fees and costs, by reason of the Contractor's acts, negligence, willfulness or failure to perform any of the obligations required by this Agreement. The Contractor at its own expense shall defend the Indemnitees in any action or suit brought against any of the Indemnitees arising out of the Contractor's acts, negligence, willfulness or failure to perform any of the obligations required by this Agreement. Any acts, negligence, willfulness or failure to perform any of the obligations required by this Agreement on the part of any agent, servant, employee or Subcontractor of the Contractor, or any Subcontractor's agent, servant or employee, are deemed to be the Contractor's acts, negligence, willfulness or failure to perform any of the obligations defined by this Agreement.

3.15.2 In claims against any person or entity indemnified under subsection 3.15.1 by an employee of the Contractor, a Subcontractor, anyone directly or indirectly employed by them, or anyone for whose acts they may be liable, the indemnification obligation under subsection 3.15.1 shall not be limited by a limitation on the amount or type of damages, compensation or benefits payable by or for the Contractor or a Subcontractor under workers or workmen's compensation acts, disability benefit acts or other employee benefit acts.

3.15.3. The College may retain such moneys due or to become due the Contractor under this Agreement as it considers necessary until such suits or claims for damages have been settled or otherwise disposed of and satisfactory evidence to that effect has been furnished to the College.

3.15.4. The provisions of this Article shall survive the termination of the Agreement.

ARTICLE 4 – ADMINISTRATION OF THE CONTRACT

4.1. CLARIFYING INSTRUCTIONS

4.1.1. The College shall be the final interpreter of the Contract Documents. Through the College's Representative and/or Construction Manager, the College will furnish with reasonable promptness such clarifications as it may deem necessary for the proper execution of the Work. Except as otherwise expressly provided in the Contract Documents, all decisions by the Architect/Engineer, College's Representative and/or Construction Manager with cost or schedule ramifications are subject to approval by the College. The Work shall be executed in conformity therewith and the Contractor shall do no work without proper drawings and instructions. The Architect/Engineer, College's Representative and/or Construction Manager have no authority to waive or change the requirements of the Contract Documents except to make minor changes in the Work, not involving extra cost or time nor inconsistent with the intent of the Contract Documents.

4.1.2. Wherever typical parts or sections of the Work are completely detailed on the drawings and other parts or sections which are essentially of the same construction are shown in outline only, the complete details shall apply to the Work which is shown in outline.

4.1.3. Dimensions of work shall not be determined by scale or rule. Figured dimensions shall be followed at all times. If figured dimensions are lacking on drawings, the Architect/Engineer shall supply them on request to the Contractor.

4.2. REQUESTS FOR INFORMATION

4.2.1. In the event that the Contractor requires clarifications on or discovers conflicts or discrepancies in the Contract Documents, the Contractor shall submit a "Request for Information", in a format suitable, to the College's Representative and/or Construction Manager and Architect/Engineer prior to proceeding with the work.

4.2.2. Unless otherwise indicated in the Contract Documents, the Contractor shall prepare and routinely update an RFI log indicating the status of RFIs.

4.2.3. The Contractor must allow the Architect/Engineer, College's Representative and/or Construction Manager and the College a reasonable time following receipt of each RFI to review the documents and respond to the Contractor. To the extent that additional time for review is needed to clarify the information submitted by the Contractor or its Subcontractors and suppliers, the Contractor will be notified of the cause of the delay and advised of how long it will take to complete the review; provided, however, that mere failure to give the Contractor such notice shall not entitle the Contractor to compensation or a time extension. The Architect/Engineer will return the completed RFI response to the Contractor and also provide one copy each to the College and College's Representative and/or Construction Manager.

4.2.4. The Contractor shall perform no portion of the Work requiring RFI response until the respective RFI response has been issued by the Architect/Engineer. Work performed without approval shall be at the Contractor's risk.

4.2.5. Should the Contractor consider any RFI response to cause an increase or decrease in the scope of the Work from that required by the Contract Documents, then the Contractor shall desist from further action relative to the item in question and shall in writing (1) immediately notify the Architect/Engineer, the College and College's Representative and/or Construction Manager; and (2) furnish them, within seven (7) days, with a notice explaining the nature of the change and whether increased or decreased cost and/or time is anticipated. No Work shall be executed until the entire matter is clarified and the Contractor is ordered by the College to proceed. Failure of the Contractor to serve written notice as required above, shall constitute a waiver of any claim in relation thereto.

4.3. SITE VISITS AND OBSERVATIONS

4.3.1. The College's Representative and/or Construction Manager, and Architect/Engineer shall at all times have access to the Work wherever it is in progress. The Contractor shall provide proper and safe facilities for such access and for visits at the place of manufacture or elsewhere.

4.3.2. Inspections by the College's Representative and/or Construction Manager, or Architect/Engineer are for the sole benefit of the College. If the Specifications, the College's, College's Representative and/or Construction Manager's, and Architect/Engineer's instructions, laws, ordinances or any public authority require any Work to be specially tested or reviewed, the Contractor shall give the College's Representative and/or Construction Manager timely notice of the Work's readiness for inspection. If the Work is scheduled to be inspected by an authority other than the College's Representative and/or Construction Manager, and Architect/Engineer, the Contractor shall inform the College's Representative and/or Construction Manager of the date fixed for such inspection. Required certificates of inspection shall be secured by the Contractor. Inspections by the College's Representative and/or Construction Manager and Architect/Engineer shall be made promptly and where practicable, inspections may be made at the source of supply.

4.3.3. If any Work has been covered up contrary to the requirements of the Contract Documents or instructions of the College's Representative and/or Construction Manager or Architect/Engineer before it has been observed, such Work must, if required by the College's Representative and/or Construction Manager and/or Architect/Engineer, be uncovered for observation and replaced and/or recovered, at the Contractor's expense.

4.3.4. If any questioned Work has been covered up which is not required to be observed by the College's Representative and/or Construction Manager and/or Architect/Engineer prior to being covered, the College's Representative and/or Construction Manager and/or Architect/Engineer may request to see the Work in question and it shall be uncovered by the Contractor as directed. If such Work is found to be in accordance with the requirements of the Contract Documents, the College shall reimburse the Contractor for the cost of such uncovering and recovering. Such reimbursement shall be for the direct cost incurred plus the contract's approved percentage for overhead and profit. If the Work is found to be not in accordance with the requirements of the Contract Documents, the Contractor shall pay all costs of uncovering, correction and recovering.

4.3.5. The Contractor shall place its field engineers at the College's Representative and/or Construction Manager's or Architect/Engineer's disposal for field checking during any inspection period. When layouts of the building and site work are to be made, the Contractor shall notify the College's Representative and/or Construction Manager and Architect/Engineer in sufficient time so that the College's Representative and/or Construction Manager and Architect/Engineer may be present.

4.3.6. Neither the presence nor the absence of the College's Representative and/or Construction Manager or Architect/Engineer on the job shall relieve the Contractor from responsibility to comply with the provisions of the Contract Documents, nor from responsibility to remove and replace Work not in accordance therewith.

4.4. CLAIMS AND DISPUTES

4.4.1. Definition of Claim

4.4.1.1. A Claim is a demand or assertion by one of the parties seeking, as a matter of right, adjustment or interpretation of Contract terms, payment of money, extension of time or other relief with respect to the terms of the Contract. The term "claim" also includes other disputes and matters in question between the College and Contractor arising out of or relating to the Contract. Claims must be made by written notice. The responsibility to substantiate claims shall rest with the party making the claim.

4.4.2. Claims for Concealed or Unknown Conditions

4.4.2.1. If conditions are encountered at the site which are (1) subsurface or otherwise concealed physical conditions which differ materially from those indicated in the Contract Documents or (2) unknown physical conditions of an unusual nature which differ materially from those ordinarily found to exist and generally recognized as inherent in construction activities of the character provided for in the Contract Documents, then the Contractor shall give notice to the College's Representative and/or Construction Manager promptly before conditions are disturbed and in no event later than fifteen (15) calendar days after first observance of the conditions. Upon receipt of such notice the College's Representative and/or Construction Manager and Architect/Engineer will promptly investigate such conditions and if they differ materially and cause an increase or decrease in the Contractor's cost of, or time required for, performance of any part of the Work will determine an equitable adjustment in the Contract Sum or Contract time or both. No change in the Contract Sum or Contract time or both will be allowed except by formal approval of the College. If it is determined that the conditions at the site are not materially different from those indicated in the Contract Documents and that no change in the terms of the Contract is justified,

the College's Representative and/or Construction Manager shall so notify the Contractor in writing stating the reasons. Claims by Contractor which dispute such a determination must be made in accordance with subsection 4.4.5.

4.4.3. Claims for Extension of Time

4.4.3.1. If the Contractor is delayed at any time in the progress of the Work by any act or omission of the College, or its employees or by any other contractor employed by the College, or by changes ordered in the Work, or by strikes, lockouts, fire, unavoidable casualties, or any causes beyond the Contractor's control, or by delay authorized by the College pending a decision, or by any cause which the College shall decide to justify the delay, the time of completion shall be extended for such reasonable time as the College may decide.

4.4.3.2. The Contractor may be entitled to a time extension, but no additional compensation, if the delay in the completion of the Work arises from unforeseeable causes beyond the control and without the fault or negligence of the Contractor, including but not restricted to, acts of God, acts of the public enemy, acts of another contractor in the performance of a contract with the College, fires, floods, epidemics, quarantine restrictions, strikes, foreign embargoes, unusually severe weather, or delays of Subcontractors or suppliers arising from unforeseeable causes beyond the control and without the fault or negligence of both the Contractor and the Subcontractor or suppliers, the time of completion shall be extended for such reasonable time as the College may decide.

4.4.3.3. Claims for extension of time will be considered by the College only if made in writing to the College. Any claim for an extension of time must be made within seven (7) calendar days of the occurrence of conditions which in the opinion of the Contractor warrant such an extension. In the case of a continuing cause of delay, only one claim is necessary. Within thirty (30) days of filing a time extension claim notice, the Contractor shall submit a clear written statement and relevant supporting documentation substantiating the claim. The documentation shall include a revised schedule, which conforms with the schedules submitted each month with the payment requests and which shows the duration of the delay, its relation to other activities, and how the alleged delay was on the critical path. No time extension will be allowed except by formal approval of the College. The College with advice and assistance from the College's Representative and/or Construction Manager shall ascertain the facts and the extent of the delay and extend the time for completing the Work, when in the College's judgment the findings of fact justify such an extension. The College's findings of fact shall be final and conclusive on the parties, subject only to appeal as provided in section 4.5 of this Contract.

4.4.4. Claims for Equitable Adjustment for Delay

4.4.4.1 If a Delay in completion of the Work is authorized in writing by the College and compensation is not provided for under Changes in the Work otherwise negotiated, and the Contractor's work is materially affected by that Delay, then the Contractor may be entitled to submit a claim for an equitable adjustment in compensation.

4.4.4.2 Schedule management within the contract duration established at time of Bid, including decisions that may delay sequencing of all or part the work, does not constitute grounds for an Equitable Adjustment for Delay claim from Contractor or his subcontractors or vendors. All prices are firm for the duration of the overall contract term.

4.4.4.3 Only the following items may be recoverable by the Contractor as compensation or damages for delay:

- (1) direct costs, consisting of
 1. actual additional salaried and non-salaried on-site labor expenses;
 2. actual additional costs of materials;

3. actual additional equipment costs, based solely on actual ownership costs of owned equipment or actual reasonable costs of rented or leased equipment;
 4. actual additional extended field office expenses, excluding those which are to be included in overhead;
 5. actual additional reasonable costs of subcontractor and suppliers at any tier for which the Contractor is liable;
- (2) actual additional costs proven by clear and convincing evidence, resulting from labor or other inefficiencies proven by clear and convincing evidence; and
 - (3) an additional percentage for overhead and profit of 15% for actual additional Work performed by the Contractor's own forces and 5% for actual additional Work performed by a Subcontractor.

4.4.4.4. No claim under this subsection shall be allowed for any costs incurred more than twenty days before the Contractor shall have notified the College in writing of the Delay.

4.4.4.5. No other compensation or damages are recoverable by Contractor for compensable delays or extensions of the completion time except as expressly stated herein. In particular, the College will not be liable for the following (by way of example and not of limitation) whether claimed by the Contractor or by a Subcontractor or supplier at any tier: (a) profit in excess of that provided herein; (b) loss of profit; (c) home office or other overhead in excess of that provided herein; (d) overhead calculated by use of the Eichleay formula or similar formulae; (e) consequential damages of any kind, including loss of additional bonding capacity, loss of bidding opportunities, and insolvency; (f) indirect costs or expenses of any nature except those expressly provided for herein; and (g) attorneys fees, costs of claims preparation and presentation, and costs of litigation.

4.4.4.6. There shall be deducted from the compensation payable to the Contractor under this section for delay any and all costs, expenses, and overhead recovered or recoverable by the Contractor under change orders issued to the Contractor or otherwise recovered or recoverable by the Contractor.

4.4.4.7. Contractor shall be entitled to no compensation or damages for delay unless, within seven (7) calendar days of the act, omission, occurrence, event or other factor alleged to have caused the delay, the Contractor notifies the College in writing of (a) the alleged delay and its anticipated duration; and (b) the act, omission, occurrence, event or other factor allegedly causing the delay. Knowledge on the part of the College or College's Representative and/or Construction Manager of the act, omission, occurrence, event, or other factor or of the delay allegedly resulting there from, shall not excuse Contractor's failure to give the College the notice required by this subsection.

4.4.5. Claims and Disputes Procedure

4.4.5.1. Unless a lesser period is prescribed by the Contract, the Contractor shall file a written notice of claim relating to the Contract, to the College's Representative within fifteen days after the basis of the claim is known or should have been known, whichever is earlier.

Contemporaneously with, or within thirty days of filing of a notice of claim, but no later than the date that final payment is made, the Contractor shall submit the claim to the College's Representative. The claim shall be in writing and shall contain:

- (1) an explanation of the claim, including references to all Contract provisions upon which it is based;
- (2) the amount of the claim;
- (3) the facts upon which the claim is based; and
- (4) all pertinent data and correspondence that the Contractor relies upon to substantiate its claim. The Contractor shall submit such additional information as may be

requested by the College's Representative.

4.4.5.2. A notice of claim or a claim that is not filed within the time prescribed by subsection 4.4.5.1 or a lesser period prescribed elsewhere in the Contract shall be dismissed and the claim shall be considered to be waived.

4.4.5.3. Upon receipt of the Contractor's claim, the College's Representative and/or Construction Manager, shall take steps deemed necessary to review and investigate the claim. These steps may include an investigation and review of the facts pertinent to the claim, requesting additional information or substantiation from the Contractor or anyone else and taking such other steps as the College's Representative may consider appropriate.

4.4.5.4. The College's Representative and/or Construction Manager shall prepare a decision in consultation with the Associate Vice President for College Facilities, or a designee. The College's Representative shall issue a written decision which shall contain such information as it considers appropriate. The written decision, before it is issued, shall be approved by the Associate Vice President for College Facilities.

4.4.5.5. Pending resolution of a claim, the Contractor shall proceed diligently with the performance of the Contract in accordance with the College's Representative's decision, order, finding or interpretation. The Contractor shall take all reasonable action to mitigate or to avoid costs or damages for which the College may be liable. The College Representative's decision shall be final and conclusive unless the Contractor files a written appeal to the College President within fifteen days of the date of the College's Representative's decision. The Contractor shall include in its appeal to the President all of the information which it wants the President to consider in the appeal. The President in consultation with such other persons as the President deems advisable shall prepare and deliver a written decision to the Contractor. The President's response shall be the College's final decision.

4.4.5.6. If the Contractor does not appeal the College's Representative's decision to the President within the time required under subsection 4.4.5.5, then the College's Representative's decision shall be considered to be final, conclusive and binding upon the Contractor and College. There shall be no further right of review either administratively or in the courts. If the Contractor's timely appeals the College's Representative's decision to the President, the President's decision shall be considered to be conclusive and final unless within thirty days from the date of the President's decision the Contractor commences an action in the Circuit Court for Montgomery County. If no action is commenced within thirty days after the date of the President's decision, the President's decision shall be considered to be final, conclusive and binding on the Contractor and the College and the Contractor's right to appeal to the courts shall be waived.

4.4.5.7. The timely filing of a claim and the receipt of a decision by the Contractor from the College's Representative and the College's President are conditions precedent to filing an action in court. Any action which may be commenced against the College shall be filed in the appropriate state court in Montgomery County, Maryland. The Contract and disputes arising out of it shall be governed by the laws of the State of Maryland without regard to conflicts of laws provisions.

4.4.5.8. If a court action is commenced pursuant to subsection 4.4.5.7, all claims, disputes and other matters in question arising out of or related to the Contract or breach thereof shall be submitted to non-binding mediation. Such mediation shall be in the nature of settlement discussions and privileged. The location of the mediation shall be in Rockville, Maryland.

4.4.5.9. Claims by the College against the Contractor may be commenced at any time in any appropriate court without regard to the other provisions of the Contract Documents, including subsection 4.4. This right is in addition to all other rights which the College may have under the

Contract Documents.

4.5. DELAYS AND DAMAGES

4.5.1. Delays beyond the control of the Contractor

4.5.1.1. In the event the performance of work or services under this Agreement is delayed by causes beyond the control of and without the fault or negligence of the Contractor, the College shall have the option to:

- (1) Terminate the Agreement, or
- (2) Allow the President of the College or his designee to extend the time for performance. No monetary compensation will be awarded for the time extension.

4.5.1.2. Any changes made in this Agreement as a result of delay shall be in writing. In the event the time for performance of this Agreement is extended beyond the term provided for, all other terms and conditions shall remain in full force and effect.

4.5.2. No Waiver of Delay

4.5.2.1. Except as may be expressly agreed otherwise by the College in writing, no action or inaction by the College or its representatives shall constitute a grant of an extension of the completion date or the waiver of a delay or other default by the Contractor, including: (1) schedule, a recovery schedule, or an anticipated completion date from Contractor; (2) allowance, approval or acceptance of any schedule; (3) failure to terminate for default at an earlier date; or (4) demand that the Contractor finish the project by the required completion date or by any subsequent date promised by the Contractor.

4.5.3. Mitigation of Delays and College Remedies.

4.5.3.1. If Contractor should at any time cause interference, stoppage or delay to the Project or any activity necessary to complete the Project by the time required by this Contract (collectively, "Delay"), Contractor shall take all reasonable action to avoid or mitigate the effects the Delays, including but not limited to: (1) rescheduling or re-sequencing the Work and (2) re-assigning personnel. When the Contractor is responsible for any Delay, the College may order the Contractor to accelerate construction, work overtime, add additional shifts or manpower, work on weekends, or to do anything else reasonably necessary in order to finish on time, at no additional cost to the College. The Contractor does not have the unilateral right to complete the Work late and pay liquidated or other damages.

4.5.3.2 If Contractor should at any time cause the Delays described in subparagraph 4.5.3.1, then in addition to any other remedies the College may have under the Contract, the College, after notifying Contractor that it has forty-eight (48) hours within which to cure the Delay, may attempt to remedy the Delay by whatever means the College may deem necessary or appropriate including, but not limited to, correcting, furnishing, performing or otherwise completing the Work, or any part thereof by itself or through others, (utilizing where appropriate, any materials and equipment previously purchased for that purpose by Contractor), or by supplementing the Contractor's forces. The Contractor shall be liable to College for all costs incurred by College in attempting to remedy the Delay. The College may deduct the cost to remedy the Delay from any monies due or to become due to Contractor.

4.5.4. Waiver of Right to a Time Extension

4.5.4.1. Failure of the Contractor to request a time extension within seven (7) calendar days of the time the Contractor should have known about the delay to which it might otherwise be entitled, shall constitute a waiver of the Contractor's right to an extension of the required completion date, except that subsection 4.5.5 shall be separately applied if necessary.

4.5.5. Severe Weather Delays

4.5.5.1. "Unusually severe weather" is weather which is more severe than the ten year average for the month as evidenced by the U.S. Weather Bureau for the locality of the Work. Time extensions for unusually severe weather will be allowed on a tentative basis only and the final decision will be reserved until the Work is substantially completed. Weather conditions prevailing throughout the entire Contract period will be considered, including consideration for abnormally mild conditions to offset abnormally severe conditions. Extension of time due to abnormal weather conditions will be granted on the basis of one (1) calendar day for each normal working day lost, or as mutually agreed upon by the College and the Contractor. No additional compensation will be provided to the Contractor.

4.5.6. Liquidated Damages

4.5.6.1. It is agreed that time is of the essence and therefore the College will suffer substantial damages if the Work is not completed within the time stated in the Preliminary Project Schedule contained in the Contract Documents. For each day that the Work shall be uncompleted after the contract completion date, the Contractor may be liable for liquidated damages in the amount specified in the Contract Documents. Prior to and after expiration of the Contract completion time, the College may withhold an amount equal to liquidated damages whenever the progress of construction is such that, due to the fault or responsibility of the Contractor, the Contractor, in the judgment of the College is behind schedule so as not reasonably to be able to permit completion of the Project on time. Due account shall be taken of excusable delays, any extensions of time reasonably due the Contractor for completion of additional Work under change orders, and for delays for which the College is responsible, provided that the Contractor has properly requested time extensions therefore. After submission of a bid, the Contractor may not contest the reasonableness of the amount of liquidated damages stated in the Contract. These assessed damages shall not be considered as a penalty, but as mutually agreed upon as the ascertained damages suffered by the College because of the delay.

ARTICLE 5 – CONSTRUCTION BY COLLEGE OR BY SEPARATE CONTRACTORS

5.1 SEPARATE CONTRACTS

5.1.1. The College reserves the right to let other contracts in connection with the Project. The Contractor shall afford other contractors reasonable opportunity for the introduction and storage of their materials and for the execution of their work, and shall properly connect and coordinate its Work with theirs. The Contractor shall work harmoniously with other contractors. The Contractor is entitled to no overhead, profit, or other compensation for work done for the College by other contractors.

5.1.2. If any part of the Contractor's Work depends for proper execution or result upon the work of any other contractor, the Contractor shall inspect and measure the work of the other contractor and promptly report to the College's Representative and/or Construction Manager any defects or discrepancies in such work. The Contractor's failure to inspect and make such report shall constitute an acceptance of the other contractor's work as fit and proper for the proper execution of its Work, except as to latent defects.

5.1.3. The College's Representative and/or Construction Manager will schedule and coordinate the Work of the Contractor with the work of all separate contractors on the Project including use of the site by

Contractor and the separate contractors. The College's Representative and/or Construction Manager will keep the Contractor informed of the progress schedule to enable the Contractor to reasonably plan and perform its Work properly. The College's Representative and/or Construction Manager may issue appropriate directions and require the Contractor to take such other measures as may be necessary to timely coordinate and progress the Work. Any neglect or refusal by the Contractor to comply with directions issued by the College's Representative and/or Construction Manager shall constitute a failure to perform the Work in accordance with the Contract requirements and will justify action from withholding of payments otherwise due up to and including termination of the Contract.

5.1.4. The College and College's Representative and/or Construction Manager do not guarantee the unimpeded operations of the Contractor. The Contractor acknowledges that the award of more than one contract for a Project necessitates the proper scheduling and sequencing of the Work with the work of all other contractors, and may lead to inherent delays in the progress of the Work. The Contractor agrees to re-sequence his work as may be reasonably directed by the College's Representative and/or Construction Manager from time to time. The Contractor hereby agrees to make no claim for delays caused by the presence or operations of other contractors engaged on the Project.

5.1.5. Should the Contractor sustain any damage through any act or omission of any other contractor having a contract with the College for the performance of work on the Project, or through any act or omission of a subcontractor of such other contractor, the Contractor shall have no claim against the College, its consultants (including but not limited to the Architect/Engineer and College's Representative and/or Construction Manager) for such damage, but shall have a right to recover such damage from the other contractor under a provision similar to subparagraph 5.1.6 which has been or will be inserted in all contracts with such other contractors. The Contractor hereby releases the College, College's Representative and/or Construction Manager and Architect/Engineer and their respective officers and employees from all damages to the Contractor caused by contractors on the Project.

5.1.6. Should any other contractor under contract with the College for performance of work on the Project sustain any damage through any act or omission of the Contractor hereunder, or through any act or omission of a Contractor's subcontractor of any tier, the Contractor agrees to reimburse such other contractor for all such damages and to indemnify and hold the College, College's Representative and/or Construction Manager and Architect/Engineer harmless from all such claims, including attorneys' fees, to fullest extent permitted by law.

5.1.7. The Contractor agrees that in event of dispute as to cooperation or coordination with adjacent contractors the College's Representative and/or Construction Manager will act as referee and decisions made by the College's Representative and/or Construction Manager will be binding.

5.1.8. The Contractor shall fully cooperate and coordinate its Work with other contractors working on separate projects for other buildings, road work, and the like in accordance with College's Representative and/or Construction Manager's direction.

5.1.9. Wherever work being done by any contractors or subcontractors is contiguous to Work covered by the Contract Documents, the respective rights of the parties shall be established by the College's Representative and/or Construction Manager to secure the completion of the various portions of the Work in general harmony.

5.1.10. If a dispute arises among the Contractor, and other contractors as to the responsibility under their respective contracts for maintaining the premises and surrounding area free from waste materials and rubbish as described in General Conditions, the College's Representative and/or Construction Manager may direct who shall perform the clean up. The College's Representative and/or Construction Manager reserves the right to clean up and allocate the cost in a timely manner among those responsible as the College's Representative and/or Construction Manager determines to be just.

ARTICLE 6 – CHANGES IN THE WORK**6.1. CHANGES IN THE WORK****6.1.1. Changes**

6.1.1.1. The College unilaterally may, at any time, without notice to the sureties, if any, and without invalidating the Contract Documents, by written order designated or indicated to be an order, make any change in the Work including but not limited to changes in the Specifications, Drawings in the method or manner of performance of the Work, the College-furnished facilities, equipment, materials, services, or site or directing acceleration in the performance of the Work. Any other written order or an oral order, including a direction, instruction, interpretation, or determination from the College that causes or constitutes any such change shall be treated as a change order under this clause provided that before performing the Work directed by the change that the Contractor gives the College's Representative and/or Construction Manager written notice stating the date, circumstances and source of the order and that the Contractor regards the order as a change order. The Contractor shall not proceed to perform the Work described in the written or oral order unless the College's Representative and/or Construction Manager acknowledges in writing to the Contractor that the order is a change order and that the Contractor is to proceed with the Work as a change.

6.1.1.2. If any change under this subsection causes an increase or decrease in the Contractor's cost of, or the time required for, the performance of any part of the Work under the Contract, whether or not changed by an order, an equitable adjustment shall be made and the Contract modified in writing accordingly; provided, however, except for claims based on defective Specifications or Drawings, that no claim for any order under subsection 6.1.1.1 above shall be allowed for any cost incurred more than twenty days before the Contractor gives written notice as therein required; and provided further that in the case of defective Specifications or Drawings for which the College is responsible, the equitable adjustment shall include any increased costs reasonably incurred by the Contractor in attempting to comply with such defective Specifications or Drawings.

6.1.1.3. If the Contractor intends to assert a claim for an equitable adjustment under subsection 6.1.1, it shall, within thirty days after receipt of an order for the furnishing of written notice under subsection 6.1.1.1 submit to the College's Representative and/or Construction Manager a written statement setting forth the general nature of the monetary extent of the claim.

6.1.2. Disputed Work

6.1.2.1. In the event of a dispute between the College and the Contractor as to whether any Work is included in the scope of the Contract, such that the Contractor will be obligated to provide that Work at no additional cost to the College, the College's Representative and/or Construction Manager may order the Contractor in writing under this section to perform the Work. If the Contractor considers such an order to be a change in the scope of the Contract entitling the Contractor to additional compensation, a time extension, or other relief, the Contractor must provide notice within seven days (7) from receipt of the College's Representative and/or Construction Manager's written order under the section to perform the Work and to initiate a claim therefore in accordance with Contract requirements.

6.1.2.2. A request by the Contractor for additional time or additional costs caused by the impact of an order of the College on the critical path for completion must be accompanied by (a) a reasonably detailed description of the effect of the order on the adjusted critical path and (b) supporting documentation. The mere existence of a change order does not entitle the Contractor

to an extension of time, compensation for delay or damages or costs associated with delay. Contractor's entitlement thereto shall depend upon the effect of the change order on the adjusted critical path for completion and shall be subject to the requirements of Article 3.7, Prosecution and Progress of the Work.

6.1.2.3. Upon receipt of a signed written order of the College's Representative and/or Construction Manager under this subsection, the Contractor shall comply with the order promptly, within the requirements of the completion schedule, whether or not the Contractor signs or accepts the change order. Failure to comply with the order in a timely manner shall constitute a breach of the Contract and grounds for termination for default or any other remedy available to the College.

6.1.3. Modification of Contract Sum

6.1.3.1. When changes in the Work may require a modification of the Contract Sum, the Contractor shall provide to the College's Representative and/or Construction Manager, within thirty (30) days of its receipt of a proposal request, an itemized breakdown showing quantities, unit costs, hours and rates of labor, and other costs in such detail as may be required to allow the reasonableness of the cost to be established. Similar cost information covering Subcontractor's Work shall be included as part of the Contractor's proposal. Minimum charges for "handling" will not be acceptable. Charges for general supervision and management will not be acceptable.

6.1.3.2. Modification of the Contract Sum, when required, shall be determined as follows:

- (1) When applicable unit prices are stated in the Contract or have been subsequently agreed upon, by application of such unit prices.
- (2) A lump sum price agreed upon by the College and the Contractor.
- (3) If job conditions or circumstances or the extent or nature of the change, or failure of the College and the Contractor to agree upon a lump sum price or the application of unit prices, prevent the determination of the cost of any proposed change, the Work shall be paid pursuant to subsection 6.1.3.4.
- (4) If a change involves a credit to the College, unless the amount must be determined by the application of unit prices, the amount of the credit shall be the greater of (a) the alternate or other itemized price for such Work stated in Contractor's bid or (b) a reasonable price, including profit and overhead.
- (5) If the change involves both a credit and a debit, the sums shall be shown and the two sums balanced to determine the adjusted total cost or credit.
- (6) The mark up allowable to the Contractor for combined overhead and profit for Work performed solely by the Contractor with its own forces shall be a reasonable amount not to exceed 15% of the Contractor's costs (excluding items includable in overhead).
- (7) The mark up allowable to a Subcontractor for combined overhead and profit for Work performed solely with its own forces shall be a reasonable amount not to exceed 15% of the Subcontractor's cost of labor and materials and equipment. Mark ups for Sub-subcontractors or suppliers, if required, must be provided from within the markup allowance provided to the Subcontractor. No additional mark up allowance will be allowed for Sub-subcontractors or suppliers. For Work performed by a Subcontractor solely with its own forces, the Contractor is entitled to a reasonable mark up for combined overhead and profit, not to exceed 5% of the Subcontractor's labor, materials and equipment cost.

Sample Calculation:

- A. Subcontractor's cost (LME) = A
(includes direct costs of Subsubcontractors and/or suppliers)
- B. Subcontractor's combined OH&P = 15% of A
- C. Subcontractor's Bonds and

	Builder's Risk Insurance if required	= as a % of A+B
D.	Contractor's combined OH&P	= 5% of A+B+C
E.	Contractor's Bonds and	
	Builder's Risk Insurance if required	= as a % of A+B+C+D
F.	Total Modification of Contract Sum:	= A+B+C+D+E

- (8) The Contractor shall be allowed the actual, reasonable additional cost for rental of machine power tools or special equipment, including fuel and lubricants which are necessary to execute the Work required on the change, but no percentage shall be added to this cost.
- (9) The Contractor and separately bonded subcontractors, if any, shall be allowed the actual, reasonable additional cost for Bonds and Builder's Risk Insurance, if required.

6.1.3.3. The allowable percentages for cost and overhead and profit as provided in subsections 6.1.3.2 (6) and (7) and elsewhere are deemed to include but not be limited to all costs and expenses of the following kinds: project management, supervision and coordination; job supervision and field office expenses required by the Contract; expenses for supervisors, superintendents, managers, timekeepers, clerks and watchmen; cost of correspondence of any kind; insurance not specifically mentioned herein; all expenses in connection with the maintenance and operation of the field office, use of small tools, cost of vehicles generally used for transporting either Workers, materials, tools or equipment to job location and incidental job burdens; and all expenses or maintenance for operation of Contractor's regularly established principle office, branch office, similar facilities and all other costs and expenses customarily classified as overhead. The Contractor's entitlement to compensation or additional time for delays for which the College is responsible or for which an extension is due to the Contractor is also subject to Article 4.5.

6.1.3.4. If the Contractor does not respond promptly or disagrees with the method for adjustment in the Contract Sum, the method and the adjustment shall be determined by the College on the basis of reasonable expenditures and savings of those performing the Work attributable to the change, including in case of an increase in the Contract Sum, a reasonable allowance for overhead and profit as stated in subsection 6.1.3.2 (6) and (7). In such a case, the Contractor shall keep and present in such form as the College's Representative and/or Construction Manager may prescribe an itemized accounting together with appropriate supporting data. The itemized accounting shall be prepared daily and presented to the College's Representative and/or Construction Manager at the conclusion of each day. Unless otherwise provided in the Contract Documents, reimbursable costs to the Contractor shall be limited to the following:

- (1) Costs of labor, including Social Security, old age and unemployment insurance, fringe benefits required by agreement or custom and Workers' compensation insurance;
- (2) Costs of materials, supplies and equipment, including cost of transportation, whether incorporated or consumed;
- (3) Rental costs of machinery and equipment exclusive of hand tools, whether rented from the Contractor or others; and
- (4) Cost of premiums for all bonds and insurance and permit fees related to the Work, provided that, the penal sum of the surety bond has been increased and the surety has increased the premium cost to the Contractor.
- (5) Pending final determination of the costs accumulated pursuant to subsection 6.1.3.4, amounts not in dispute may be included in an Application for Payment.

6.1.4. Minor Changes in the Work

6.1.4.1. The College's Representative will have authority to order minor changes in the Work not involving adjustment in the Contract Sum or extension of the Contract time and not inconsistent with the intent of the Contract Documents. Such changes shall be effected by written order of the College's Representative and/or Construction Manager and shall be binding on the College and

Contractor. The Contractor shall carry out such written orders promptly.

ARTICLE 7 – PAYMENTS AND COMPLETION

7.1. SCHEDULE OF VALUES

7.1.1. To facilitate checking the Work performed, the Contractor shall furnish to the College's Representative and/or Construction Manager a detailed Schedule of Values of the various parts of the Work, including quantities, aggregating to the total sum of the Contract. The schedule shall be divided so as to facilitate payments to Subcontractors, if any, made out in the form prescribed by the College's Representative and/or Construction Manager, and, if required, supported by such evidence of its correctness as the College's Representative and/or Construction Manager may direct. The Schedule of Values cost breakdown shall be used as a basis for Certificates of Payment unless it is found to be in error.

7.1.2. The Schedule of Values shall be submitted as soon as possible, but not less than fifteen (15) days prior to the first scheduled Application for Payment described in the General Conditions.

7.2. PROGRESS PAYMENTS

7.2.1. Application for Payment

7.2.1.1. No later than the 25th day of each month, the Contractor shall submit to the College's Representative and/or Construction Manager an original and accurate Application for Payment dated the last day of the month in the form prescribed by the Contract Documents together with the supporting documentation listed herein. Applications for Payment received after the 25th day of each month, not submitted on an original, containing erroneous information, and missing the required support documents shall not be processed during that month's payment cycle. Payments shall be made on the value of Work expected to be completed up to the last day of the month based upon the labor and materials incorporated in the Work; and of materials suitably stored at the site; less the aggregate of any previous payments, retainages and amounts withheld under subsection 7.2.1.9. The Applications for Payment, including final payment, shall be reviewed and certified by the College's Representative and/or Construction Manager. After reviewing and certifying the amounts due the Contractor, the College's Representative and/or Construction Manager will submit the Project Application and the Project Certificate for Payment, along with the Contractor's Applications and Certificates for Payment, to the Architect/Engineer. Based on the Architect/Engineer's observations and valuations of Contractor's Applications for Payment, and the Certifications of the College's Representative and/or Construction Manager, the Architect/Engineer will review and certify the amounts due the Contractor and will issue a Project Certificate for Payment.

- (1) The Contractor shall promptly pay each Subcontractor, if any, upon receipt of payment from the Owner, out of the amount paid to the Contractor on account of such Subcontractor's Work, the amount to which the Subcontractor is entitled, reflecting the percentage actually retained, if any, from payments to the Contractor on account of the Subcontractor's Work. The Contractor may not withhold from the Subcontractor any portion of the payment due to any cause unrelated to the Subcontractor's performance of the Work on the Project, notwithstanding any prior agreement between Contractor and Subcontractor to the contrary.

7.2.1.2. No later than the 25th day of each month, each Application for Payment shall be supported by the following documentation, each in a form to be supplied or approved by the College's Representative and/or Construction Manager:

- (1) Updated schedule information of Contractor's progress to date.
- (2) Subcontractors' certificates, statements and affidavits showing that portions of the Work covered by the Application for Payment have been completed and material

included therein have been and will be delivered.

- (3) Affidavit from Contractor and Subcontractor stating respectively that their subcontractors, vendors and material suppliers have been paid from the proceeds of the last Application for Payment and that there are no outstanding claims for payment.

7.2.1.3. That part of the payment which is requested on account of materials delivered and suitably stored at the site or other approved location but not incorporated in the Work shall, if required by the College's Representative and/or Construction Manager, be conditioned upon submission by the Contractor of bills of sale or upon such other procedure as will establish the College's title to such material or otherwise adequately protect the College's interest as determined by the College's Representative and/or Construction Manager, including applicable insurance coverage and cost of transportation to the project site for those materials and equipment stored off the site.

7.2.1.4. From each Application for Payment the College shall withhold 10% of the amount earned as retainage. Upon request by the Contractor and approval by the College, and, if required, the surety, and if the progress of the Work and quality of the Work is in accordance with the current schedule and is satisfactory as determined by the College at its sole discretion, and if the Contractor's Work is physically 50% complete, no additional retainage shall be withheld for Work completed subsequent to that date. Unless otherwise agreed to by the College in writing, the retainage withheld for the first 50% of the Contractor's Work shall be paid with the Final Payment. The College reserves the right to withhold from subsequent payments for the balance of the Work a sum sufficient to restore the retainage to 10% of the value of the Work for the balance of the Work from the time it may conclude in its sole judgment that the Work may not be completed by the date required by the Contractor or the Work is otherwise not in conformance with the requirements of the Contract Documents. Unless otherwise agreed to by the College in writing, until Substantial Completion of the Project is achieved, the retainage withheld shall not be less than 5%. Following Substantial Completion of the Project, the College at its sole discretion, may authorize reduction of retainage withheld to an amount not less than two (2) times the College's Representative and/or Construction Manager's estimate of the value of the Contractor's punchlist items.

7.2.1.5. Application for Payment shall be in the format required by the Contract Documents and the College's Representative and/or Construction Manager. The Application shall include an itemized breakdown of the various items of the Work based on the previously submitted Schedule of Values.

7.2.1.6. The provisions for payment, withholding, retainage and Certificates of Payments are solely for the benefit of the College, and no other party (including sureties of the Contractor) may assert any claim for negligence or other action against the College, or anyone acting on behalf of the College for waiving or misapplying these provisions.

7.2.1.7. No Certificate issued nor payment made to the Contractor may be construed as an acceptance of the Work or be construed or relied upon as any indication that the labor or materials are in accordance with the Contract Documents or that the amounts paid or certified therefore represent the correct cost or value of the Work or that such amounts are in fact or law due the Contractor.

7.2.1.8. Any Application for Payment which is based on a pending claim for additional compensation may be certified by the College's Representative and/or Construction Manager and the Architect/Engineer to the extent that it is determined that the payments yet to be made under the Contract and/or the retainage are sufficient to protect the College. Nothing herein shall be construed as requiring the College's Representative and/or Construction Manager and Architect/Engineer to certify such applications or to delete the retainage. All certifications and

payments, including that pursuant to a pending claim, shall be tentative and conditional.

7.2.1.9. The College may withhold payment or, on account of subsequently discovered evidence, nullify or reduce the whole or part of any certificate or payment on account of:

- (1) failure to update schedules properly as required by subsection 3.7;
- (2) failure to furnish the documents required by subsection 7.2.1.1 and 7.2.1.2;
- (3) liquidated damages which may be assessed under the Contract Documents or other damages or compensation due the College for claims of the College against the Contractor;
- (4) the cost (measured by the contract value or fair market value whichever is greater) of completing unfinished or defective Work not remedied or deductions or amounts due the College under the Contract;
- (5) failure of the Contractor to perform any material Contract requirements;
- (6) claims filed or likely to be filed against the College for which the Contractor may be liable to the College;
- (7) failure of the Contractor to make payments properly to Subcontractors or suppliers for material or labor or amounts claimed by the Contractor's surety or insurer under any right of subrogation;
- (8) a reasonable doubt that the Contract can be completed for the balance then unpaid;
- (9) damage to another Contractor;
- (10) any claim of the College or debt owed to the College by the Contractor;
- (11) failure to maintain as-built drawings; or
- (12) the cost of completing unfinished warranty Work.

7.3. ACCEPTANCE OF THE WORK AND FINAL PAYMENT

7.3.1. Partial Acceptance

7.3.1.1. If, in its sole discretion, the College desires to occupy any portion of the Work, the College shall have the right to occupy and use those portions of the Work which in the opinion of the College can be used for their intended purpose; provided that the conditions of occupancy and use are established and the responsibilities for the Contractor and the College for maintenance, heat, light, utilities and insurance are mutually agreed to by the Contractor and the College. The College has no obligation to accept the Work in portions. Partial occupancy shall in no way relieve the Contractor of its responsibilities under the Contract.

7.3.1.2. When the College occupies the Work in portions or accepts the Work in portions, if the beneficial use of any accepted portion of the Work as a whole depends on substantial completion or beneficial use of any other portion, then, unless otherwise agreed to by the College in writing: (1) warranties on the accepted portions do not begin to run until substantial completion of all portions on which beneficial use of the whole Work depends, and (2) substantial completion of the whole Work shall not be deemed to be achieved until substantial completion of all portions on which beneficial use of the whole depends.

7.3.2. Substantial Completion and Final Inspection

7.3.2.1. When the Work is substantially completed, the Contractor shall notify the College's Representative and/or Construction Manager and Architect/Engineer in writing that the Work will be ready for final inspection and testing on a definite date. Reasonable notice shall be given by the Contractor to permit the College's Representative and/or Construction Manager and Architect/Engineer to schedule the final inspection.

7.3.2.2. The inspection shall be conducted by the College's Representative and/or Construction Manager and the Architect/Engineer. On the basis of the inspection, if it is determined that the

Work appears to be substantially complete and the Work appears to be occupiable and usable for its intended purpose, the College's Representative and/or Construction Manager and Architect/Engineer shall establish the date of Substantial Completion, shall fix the times at which the warranties will begin, and the Architect/Engineer shall issue a Certificate of Substantial Completion.

7.3.2.3. If it is determined that Substantial Completion has been achieved, the College's Representative and/or Construction Manager shall fix the time within which the Contractor shall complete any remaining items of Work which will be indicated on a list (the "punch list"). If the Contractor fails to complete the remaining items so listed in the time stipulated, the College shall have the undisputed right to complete the Work at the Contractor's expense. The Contractor may be required to complete multiple punch lists until the Contract is performed in its entirety. Failure to complete punch list work in a timely manner shall constitute grounds for termination of the Contract for default. Final payment shall not be made until all Contract work, including all punch list work is complete to the satisfaction of the College's Representative and/or Construction Manager.

7.3.2.4. Acceptance of the Work as substantially complete shall not excuse or waive any failure of the Contractor to complete the Contract as required by the Contract Documents. The Work shall not be considered substantially complete until (1) all electrical, mechanical, and life safety systems shall be completed and successfully tested and successfully inspected for conformity to all requirements of the Contract Documents and all applicable codes and standards, (2) a certificate of occupancy has been obtained for all parts of the Work and (3) all other requirements for substantial completion are met.

7.3.2.5. Upon completion of the Work, the Contractor shall forward to the College's Representative and/or Construction Manager a written notice that the Work is ready for final inspection and acceptance and shall also forward to the College's Representative and/or Construction Manager a final Application for Payment. The final Application for Payment shall be processed in accordance with Subparagraph 7.3.3. Upon receipt, the College's Representative and/or Construction Manager will forward the notice and Application to the Architect/Engineer who with the College's Representative and/or Construction Manager will promptly make such inspection. When the Architect/Engineer, based on the recommendation of the College's Representative and/or Construction Manager, finds the Work acceptable under the Contract Documents, the Architect/Engineer shall issue a final certificate stating that the Work provided for in this Agreement has been completed and is acceptable under the terms and conditions thereof and that the entire balance found to be due to the Contractor and noted in the final certificate is due and payable. The College's Representative and/or Construction Manager and Architect/Engineer may not issue the final Certificate for Payment until all Work is fully completed and all other obligations of the Contractor under the Contract Documents have been completed.

7.3.3. Application for Final Payment

7.3.3.1. Upon completion of the Work, the Contractor shall prepare and submit to the College's Representative and/or Construction Manager an Application for Final Payment. The College's Representative and/or Construction Manager and Architect/Engineer will promptly proceed to make any necessary final surveys, to complete any necessary computations of quantities, and to complete other activities necessary to determine the Contractor's right to final payment. The College's Representative and/or Construction Manager and Architect/Engineer will certify so much of the Contractor's Application for Final Payment as they consider due. The Contractor shall be informed of all deductions, damages, costs, back-charges, and other charges assessed against the Contractor by the College and the reasons therefore. Notwithstanding what is stated above, prior to or in the absence of a request from the Contractor for final payment, the College may determine the amount of the final payment it considers to be due to the Contractor.

7.3.3.2. If the Contractor disputes the amount determined by the College to be due it, it may initiate a claim under Article 4.4, Claims and Disputes.

7.3.3.3. Acceptance by the Contractor of any payment identified by the College as being a final payment shall operate as an accord and satisfaction and a general release of all claims of the Contractor against the College arising out of or connected with the Contract, except as may be expressly agreed otherwise in writing between the Contractor and the College. No claims by the Contractor may be asserted for the first time after the Contractor submits its Application for Final Payment or after final payment is made by the College.

7.3.3.4. Prior to final payment and before issuance of the College's Representative and/or Construction Manager's and Architect/Engineer's final Certificates therefore, the Contractor shall fully comply with the following requirements:

- (1) Cleanup the Work area in accordance with the Specifications and federal, state, bi-county, county and local rules and regulations.
- (2) Provide a notarized affidavit stating that all monetary obligations to suppliers of material, services, labor and all Subcontractors have been completely fulfilled and discharged.
- (3) Complete all punch list Work and furnish to the College's Representative and/or Construction Manager all documents, manuals and record (as-built) documents.

7.4. ASSIGNMENT OF CONTRACT MONIES

7.4.1. The Contractor shall not assign any monies due to it under the Contract without the consent of the College, and the assignee in such case shall acquire no rights against the College.

7.5. AUDIT

7.5.1. If the Contractor has submitted any claim or request for additional payment exceeding \$50,000, or If the Contractor has submitted cost or pricing data in connection with the pricing of any modification to this Contract, the College shall have the right to examine and audit all books, records, documents, and other data of the Contractor (including computations and projections) related to negotiating, pricing or performing the modification or claim in order to evaluate the accuracy, completeness, and currency of the cost or pricing data. In addition to the above, the Contractor shall make available to the College the original project bid estimate and backup takeoffs and records, and the actual monthly or periodic job cost records. If the Contractor fails or refuses to comply with applicable provisions concerning the Contract changes or claims, the College shall have no obligation to make payment to the Contractor for the change or claim.

7.5.2. The Contractor shall permit audit and fiscal and programmatic monitoring of the Work performed under this Agreement. The Contractor shall make available at its office at all reasonable times, the materials described in subsection 7.5.1, for examination, audit or reproduction, for 3 years after final payment under the Contract.

7.5.3. If the Contract is completely or partially terminated, the records relating to the Work terminated shall be made available for 3 years after any resulting final termination settlement.

7.5.4. Records pertaining to claims, contract disputes, or to litigation or the settlement of claims arising under or relating to the performance of the Contract shall be made available until final disposition of such appeals, litigation, or claims.

ARTICLE 8 – PROTECTION OF PERSONS AND PROPERTY**8.1. SAFETY PRECAUTIONS AND PROGRAMS**

8.1.1. The Contractor shall comply with all applicable laws, ordinances, rules, regulations and lawful orders of any public authority having jurisdiction for the safety of persons or property or to protect them from damage, injury or loss.

8.1.2. The Contractor shall be responsible for initiating, maintaining and supervising all safety precautions and programs in connection with the performance of the Contract. Contractor shall comply with College's Representative and/or Construction Manager's safety program.

8.1.3. Except as otherwise directed by the Contract Documents, in the event the Contractor encounters on the site material reasonably believed to be hazardous, including but not limited to asbestos or polychlorinated biphenyl (PCB), which has not been rendered harmless, the Contractor shall immediately stop Work in the area affected and report the condition to the College's Representative and/or Construction Manager in writing. The Work in the affected area shall not thereafter be resumed except by written agreement of the College's Representative and/or Construction Manager and Contractor if in fact the material is hazardous and has not been rendered harmless. The Work in the affected area shall be resumed in the absence of hazardous material.

8.2. PROTECTION OF PERSONS AND PROPERTY

8.2.1. The Contractor shall take all necessary precautions to ensure the safety of the public and of workers on the job, and to prevent accidents or injury to any persons on, about, or adjacent to the premises where the Work is being performed. The Contractor shall comply with the "Williams-Steiger Occupational Safety and Health Act of 1970, as amended, and all laws, ordinances, codes, rules and regulations relative to safety and the prevention of accidents, and shall also comply with the "Manual of Accident Prevention in Construction" of the Associated General Contractors of America and with the applicable provisions of the American Standard Safety Code for Building Construction, ANSI A 10 Series, unless prevention of accidents is regulated by a more stringent local, State or Federal code, ordinance or law. The Contractor shall erect and properly maintain at all times, as required by laws and regulations and the conditions and progress of the Work, proper safeguards, including minimum provision of six (6) foot fall protection, for the protection of Workers and public and shall post signs and other warnings against the dangers created by openings, stairways, falling materials, open excavations and all other hazardous conditions. It shall be the Contractor's exclusive responsibility to take all safety precautions which may be necessary to protect all persons and property from injury or damage.

8.2.2. Contractor shall request permission in writing of the College's Representative and/or Construction Manager, and have received written permission from the College's Representative and/or Construction Manager, prior to the storage, use, or transportation onto the campus of explosives or other hazardous materials or equipment required for the execution of the Work. The Contractor is prohibited from storing, using or transporting hazardous materials or equipment not required for the execution of the Work on campus. The Contractor shall exercise the utmost care and shall carry on such activities under the supervision of properly qualified personnel if the written permission has been granted.

8.2.3. All damage or loss to any property referred to in this section, caused in whole or in part by the Contractor, and Subcontractor, and sub-subcontractor, or anyone directly or indirectly employed by any of them or by anyone for whose acts any of them may be liable, shall be remedied by the Contractor, except damage or loss attributable solely due to faulty Drawings or Specifications or to the acts or omissions of the College or Architect/Engineer or anyone employed by either of them or for whose acts either of them may be liable, and not also attributable to the fault or negligence of the Contractor.

8.2.4. The Contractor shall designate a responsible member of its organization at the site whose duty shall be the prevention of accidents. This person shall be the Contractor's superintendent unless otherwise designated in writing by the Contractor to the College's Representative and/or Construction Manager.

8.2.5. Contractor shall not load or permit any part of the Work to be loaded so as to endanger its safety.

8.2.6. In any emergency affecting the safety of persons or property, the Contractor shall act, at the Contractor's discretion, to prevent threatened damage, injury or loss. Any additional compensation or extension of time claimed by the Contractor on account of emergency Work shall be determined as provided for in these General Conditions.

8.2.7. The Contractor shall continuously protect the Work and the College's property from damage, injury or loss arising in connection with operations under the Contract Documents. It shall make good any such damage, injury or loss, except such as may be caused solely by agents or employees of the College.

8.2.8. The Contractor shall be solely responsible for all damage due to intrusion and for the proper protection of the project site from damage due to fire, rain, wind or other causes. The Contractor shall provide sufficient security personnel as they deem necessary for proper protection of the Work and project site at all times. The Contractor shall provide temporary protection to prevent unauthorized persons from obtaining access to the site during the night and at other non-working hours.

8.2.9. The Contractor shall assume sole responsibility for vandalism or loss of materials and equipment not covered by Contractor's Builder's Risk insurance.

8.2.10. The Contractor shall protect all streets, sidewalks, light poles, hydrants and concealed or exposed utilities of every description affected by or adjacent to the Work and if such items are damaged by the Contractor or Subcontractors, the Contractor shall make all necessary repairs thereto or replacements thereof at no cost to the College.

8.2.11. Tight wood sheathing or plywood shall be laid under any materials that are stored on finished cement surfaces.

8.2.12. The Contractor shall at all times provide and maintain adequate protection against weather so as to preserve all Work, materials, equipment, apparatus and fixtures free from injury or damage.

8.2.13. The Contractor shall provide and maintain adequate protection for all properties adjacent to the site. When required by law or for the safety of the Work, the Contractor shall shore up, brace, underpin and protect as necessary, foundations and other portions of existing structures which are in any way affected by the operations under the Contract Documents. The Contractor, before commencement of any part of the Work, shall give any notices required to be given to an adjoining landowner or other parties.

8.2.14. The Contractor shall confine its construction equipment, the storage of materials and the operations of Workers to the limits indicated by laws, ordinances, permits and as may be established by the College, and shall not unreasonably encumber the premises with construction equipment or material.

8.2.15. The Contractor shall enforce the College's Representative and/or Construction Manager's instructions regarding signs, advertisements, fires and smoking.

8.3. FIRE PROTECTION

8.3.1. Adequate precautions shall be taken against fire throughout all the Contractor's and Subcontractors' operations. Flammable material shall be kept at an absolute minimum, and, if any, shall be properly handled and stored. Except as otherwise provided herein, the Contractor shall not permit fires to be built or open salamanders to be used in any part of the Work.

8.3.2. Construction practices, including cutting and welding, and protection during construction shall be in accordance with the published standards of the Industrial Risk Insurers and the National Fire Protection Association; provide a sufficient number of approved portable fire extinguishers, distributed about the project; and use non-freeze type in cold weather.

8.3.3. Gasoline and other flammable liquids shall be stored in and dispensed from Underwriters' Laboratories listed safety containers in conformance with the National Fire Protection Association recommendations. Storage, however, shall not be within buildings.

8.3.4. All tarpaulins that may be used for any purpose during construction of the Work shall be made of material which is resistant to fire, water and weather. All tarpaulins shall have the Underwriters' Laboratories approval and shall comply with FS CCC-D-746.

8.3.5. The Contractor shall maintain emergency and fire exits from the Work area, or establish alternative exits satisfactory to the Fire Marshal.

8.3.6. Fire precautions are the exclusive responsibility of the Contractor.

8.4. EMERGENCIES

8.4.1. In an emergency affecting the safety of life, the Work or adjoining property, the Contractor, without special instructions or authorization from the College's Representative and/or Construction Manager, is permitted to act at the Contractor's discretion to prevent such threatened loss or injury. In such an emergency the Contractor shall act to prevent any threatened loss or injury and shall notify the College's Representative and/or Construction Manager and the Campus Security Office of such actions.

8.5. ACCIDENTS

8.5.1. The Contractor shall provide at the site, and make available to all workers, medical supplies and equipment necessary to supply first aid service to all persons injured in connection with the Work.

8.5.2. Contractor must promptly report in writing to the College's Representative and/or Construction Manager and the Campus Security Office all accidents arising out of, or in connection with, the performance of the Work, whether on or off the site, which caused death, personal injury or property damage, giving full details and statements of witnesses. In addition, if death or serious damages are caused, the accident shall be reported immediately by telephone or messenger. If any claim is made by anyone against the Contractor or any Subcontractor on account of any accident, the Contractor shall promptly report the facts in writing to the College's Representative and/or Construction Manager and the Campus Security Office, giving full details of the claim.

ARTICLE 9 – INSURANCE AND BONDS

9.1. INSURANCE

9.1.1. Unless otherwise indicated in the Contract Documents, the Contractor shall maintain in force at all times during the term of this Agreement, with an insurance carrier licensed to do business in the State of Maryland acceptable to the College, the following minimum insurance coverage. This insurance must be kept in full force and effect during the term of this contract, including all extensions. The insurance must be evidenced by a certificate of insurance, and if requested by the College, the proposed awardees/Contractor shall provide a copy of the insurance policies. The Contractor's insurance shall be primary.

a) Worker's Compensation Insurance covering the Contractor's employees as required by State of Maryland law with the following minimum limits:

Bodily Injury by Accident	\$ 100,000 each accident
Bodily Injury by Disease	\$ 500,000 policy limit
Bodily Injury by Disease	\$ 100,000 each employee.

b) Commercial General Liability Insurance, excluding automobiles owned or hired by the Contractor, with limits as follows:

Bodily Injury and Property Damage:	\$ 10,000,000 combined single limit of bodily injury and property damage per occurrence
------------------------------------	---

c) Comprehensive Automobile Liability Insurance, providing bodily injury and property damage coverage for owned vehicles, hired vehicles and non-owned vehicles with limits as follows:

Bodily Injury:	\$ 1,000,000 each person \$ 2,000,000 each occurrence
Property Damage:	\$ 2,000,000 each occurrence

d) Builder's Risk Insurance, providing property damage and theft replacement coverage for goods provided and services rendered during construction. For building renovation projects, when custody of the building is turned over to the Contractor, the Builder's Risk policy must additionally include building replacement value.

e) Insured - The College, its elected and appointed officials, officers, consultants, agents and employees must be named as an additional insured and loss payee on Contractor's Commercial and Excess/Umbrella Insurance for liability arising out of Contractor's products, goods and services provided under this Agreement.

9.1.2. At the time this Agreement is made, the Contractor shall provide the College with evidence of payment for the above insurance coverage as resulted by this Agreement. Any request for extension of time of this Agreement shall also include evidence of payment for the above insurance coverage as required by an extension of time for this Agreement.

9.1.3. These coverages and limits are to be considered minimum requirements under this Agreement and shall in no way limit the liability or obligations of the Contractor. The insurance shall provide that policy coverage will not be canceled, altered or materially changed without sixty (60) calendar days' prior notice to the College by registered or certified mail. The insurance shall not be limited to claims made only while the policy is in effect.

9.1.4. The Contractor shall furnish the College with a certificate of insurance as evidence of the required coverage. The certificates of insurance must name the College as an additional insured.

9.1.5. In the event that the Contractor's insurance is terminated, the Contractor shall immediately obtain other coverage and any lack of insurance shall be grounds for immediate termination of this Agreement.

9.1.6. For the purposes of this article, the word "licensed" shall be deemed to mean an insurance carrier either licensed or approved to do business in the State of Maryland.

9.2. PERFORMANCE, LABOR AND MATERIAL BONDS

9.2.1. The College may require the Contractor to furnish bonds. The bonds furnished by the Contractor shall be issued by a surety licensed to conduct business in the State of Maryland. The surety shall be approved by the College. The bonds furnished shall comply in all respects with the requirements of Maryland's Little Miller Act and shall be in the form prescribed by the College. Upon the request of any person or entity appearing to be a potential beneficiary of bonds covering payment of obligations arising

under the Contract, the Contractor shall promptly furnish a copy of the bonds or shall permit a copy to be made.

9.2.2. If at any time, the surety becomes insolvent, files for bankruptcy or for any reason whatsoever loses its right to do business in the State of Maryland, the Contractor shall, as soon as practicable but no later than within five calendar days, inform the College of this occurrence in writing.

9.2.3. If at any time, the surety becomes insolvent, files for bankruptcy or for any reason whatsoever loses its right to do business in the State of Maryland, the Contractor shall, within ten (10) calendar days after notice from the College to do so, substitute an acceptable bond (or bonds) in such form and sum and signed by such other surety as may be satisfactory to the College.

ARTICLE 10 – CORRECTION OF WORK

10.1. CORRECTION OF WORK

10.1.1. Correction of Work before Final Payment

10.1.1.1. The Contractor shall promptly remove from the premises all materials, equipment (whether incorporated in the Work or not) and Work rejected by the College's Representative and/or Construction Manager as failing to conform to the Contract Documents, and the Contractor shall promptly replace and re-execute all Work under its Contract in accordance with the Contract Documents and without expense to the College and shall bear the expense of making good all Work of other contractors destroyed or damaged by such removal or replacement.

10.1.1.2. If the Contractor fails to correct nonconforming Work and does not proceed with correction of such Work within a reasonable period fixed by written notice from College's Representative and/or Construction Manager, the College's Representative and/or Construction Manager may remove it and store the salvable materials or equipment at the Contractor's expense. If the Contractor does not pay costs of such removal and storage within ten (10) calendar days after written notice, the College's Representative and/or Construction Manager may upon ten (10) additional calendar days written notice sell such materials and equipment at auction or at private sale and shall account for the proceeds thereof, after deducting costs and damages that should have been borne by the Contractor, including compensation for the College's Representative and/or Construction Manager's and Architect/Engineer's services and expenses made necessary thereby. If such proceeds of sale do not cover costs which the Contractor should have borne, the Contract sum shall be reduced by the deficiency. If payments then or thereafter due the Contractor are not sufficient to cover such amount, the Contractor shall pay the difference to the College.

10.1.2. Correction of Work after Final Payment

10.1.2.1. If, within one year, or other time period established in the Contract Documents, after the date of Substantial Completion of the Work or designated portion thereof, any of the Work is found to be not in accordance with the Contract Documents, the Contractor, at its own expense shall correct it promptly after receipt of written notice from the College to do so. The Contractor shall pay for such tests and inspections made necessary by the faulty Work. The Contractor shall pay the costs incurred by the College for professional services and expenses, including but not limited to design professional and College's Representative and/or Construction Manager fees, required as a result of Work found not in accordance with the Contract Documents, during the correction period. The correction period shall be extended with respect to portions of Work first performed after Substantial Completion by the period of time between Substantial Completion and the actual performance of the Work. This obligation shall survive Final Completion of the Work under the Contract and the Contract Closeout.

10.2. ACCEPTANCE OF NON-CONFORMING WORK

10.2.1. If, in the opinion of the College, it is undesirable to replace any defective or damaged materials or to reconstruct or correct any portion of the Work injured or not performed in accordance with the Contract Documents, the compensation to be paid to the Contractor hereunder shall be reduced by such amount as in the judgment of the College shall be equitable. Such adjustment shall be effected whether or not final payment has been made.

ARTICLE 11 – MISCELLANEOUS PROVISIONS

11.1. LEGAL OBLIGATIONS, RELATIONS AND RESPONSIBILITIES

11.1.1. Laws to be Observed

11.1.1.1. The Contractor shall keep fully informed of all Executive Orders, Federal, State, county, bi-county, regional and local laws, ordinances, rules and regulations and all orders and decrees of bodies of tribunals having any jurisdiction or authority, which in any matter affect those engaged or employed on the Work, or which in any way effect the conduct of the Work. It shall at all times observe and comply with all such laws, rules, ordinances, regulations, orders and decrees; it shall protect and indemnify the College and its representatives against any such claim or liability arising from or based on the violation of any law, ordinance, regulation, order, or decree, whether by itself or its employees, Subcontractors or suppliers at any tier. Whenever the Contract Documents require the Contractor to comply with provisions of Federal, State or local laws, regulations, ordinances or codes, Contractor must comply whether such laws, regulations, ordinances or codes are expressly incorporated into the Contract or not.

11.1.1.2. The Contractor must comply with the provisions of the Workers' Compensation Act and Federal, State and local laws relating to hours of labor.

11.1.1.3. This Agreement is a contract under seal and its provisions shall be construed and interpreted according to the laws of the State of Maryland, without regard to principles of conflicts of law.

11.1.1.4. If the Contractor observes that the Contract Documents are at variance with any applicable law, ordinance or regulation, it shall promptly notify the College's Representative and/or Construction Manager, and any necessary change shall be adjusted as provided in the Contract for changes in the Work. If the Contractor performs any Work knowing it to be contrary to such laws, ordinances, rules and regulations, and without such notice, it shall bear all costs arising there from.

11.1.2. Regulations

11.1.2.1. Wherever any provision of any section of the Specifications conflicts with any agreements or regulations of any kind at any time in force among members of any Associations, Unions or Councils, which regulate or distinguish what work shall or shall not be included in the work of any particular, the Contractor shall make all necessary arrangements to reconcile any such conflict without delay, damage or cost to the College and without recourse to the College.

11.1.2.2. In case the progress of the Work is affected by any undue delay in furnishing or installing any items of material or equipment required under the Contract because of a conflict involving any such agreement or regulation, the College's Representative and/or Construction Manager and Architect/Engineer may require that other material or equipment of equal kind and

quality be provided at no additional cost to the College.

11.2. INDEPENDENT CONTRACTOR

11.2.1. The Contractor shall perform the Contract as an independent contractor and shall not be considered as an agent of the College nor shall any employee or agent of the Contractor be considered subagents of the College. Nothing in this Contract shall be construed as constituting a partnership, joint venture, or agency between the College and Contractor. Other than duties of the College's Representative and/or Construction Manager based on authority granted to the College's Representative and/or Construction Manager by the College, no acts performed or representations, whether oral or written, made by or with respect to third parties and the Contractor shall be binding on the College.

11.3. EQUAL OPPORTUNITY

11.3.1. During the performance of this Contract, and in accordance with applicable law, the Contractor shall not discriminate in any manner on the basis of age, sex, race, color, religious belief, national origin, creed, status as a qualified individual with a disability or handicap, pregnancy, marital status or status as a disabled veteran or veteran of the Vietnam era.

11.3.2. The Contractor shall take affirmative action to ensure that applicants are employed, and that employees are treated equally during employment without regard to their age, sex, race, color, religious belief, national origin, creed, status as a qualified individual with a disability or handicap, pregnancy, marital status or status as a disabled veteran or veteran of the Vietnam era. Such action shall include, but not be limited to the following: employment, upgrading, demotion, or transfer; recruitment or recruitment advertising; layoff or termination; rates of pay or other forms of compensation; and selection for training apprenticeship. The Contractor agrees to post in conspicuous places, available to employees and applicants for employment, notices setting forth the provisions of this non-discrimination clause.

11.3.3. During the performance of this contract, the Contractor agrees that it shall, in all solicitations or advertisements for employees placed by or on behalf of the Contractor, state that all qualified applicants shall receive consideration for employment without regard to sex, race, age, color, creed, national origin, religious belief, handicap, marital status or status as a disabled veteran or veteran of the Vietnam era. The Contractor further assures the College that, in accordance with the Immigration Reform and Control Act of 1986, it does not and will not discriminate against an individual with respect to hiring, or recruitment or referral for a fee, of the individual for employment or the discharging of the individual from employment because of such individual's national origin or in the case of a citizen or intending citizen, because of such individual's citizenship status.

11.3.4. The Contractor shall comply with all provisions of Executive Order 11246, as amended and of the rules, regulations and relevant orders of the Secretary of Labor.

11.3.5. The Contractor shall furnish all information and reports required by Executive Order 11246, as amended and by the rules, regulations and orders of the Secretary of Labor, or pursuant thereto, and shall permit access to the Contractor's books, records and accounts by the contracting agency and the Secretary of Labor for purposes of investigation to ascertain compliance with such rules, regulations and orders.

11.3.6. In the event of the Contractor's noncompliance with the nondiscrimination clauses of the contract or with any of such rules, regulations or orders, this contract may be canceled, terminated or suspended in whole or in part, or the College may take such other action as may be necessary to obtain compliance. If such noncompliance appears continuing, the College may suspend all Contract payments until the noncompliance has ceased. Any delay in completion of the Contract as the result of the College taking action to obtain compliance with the nondiscrimination clauses of this Contract shall not preclude the imposition and collection of the liquidated damages for each day of delay in completion of the Work as

provided for elsewhere in the Contract Document. The Contractor may also be declared ineligible for further contracts with the College in accordance with procedures authorized in Executive Order 11246, as amended. The College's conceptual rights and remedies provided under this section are in addition to any other rights and remedies as provided in Executive Order 11246, as amended or by rule, regulation or order of the Secretary of Labor, or as otherwise provided by law or under this Contract.

11.3.7. Subcontractors shall not be approved by the College without first agreeing to the above terms and conditions, and the Contractor shall include the provisions of subsections (1) through (7) of this section in every subcontract or purchase order unless exempted by rules, regulations or orders of the Secretary of Labor issued pursuant to Section 204 of Executive Order 11246, as amended, so that such provisions shall be binding upon each Subcontractor or vendor. The Contractor shall take such action with respect to any Subcontractor or purchase order as the College may direct as a means of enforcing such provisions including sanctions for noncompliance; provided, however, that in the event the Contractor becomes involved in, or is threatened with, litigation with a Subcontractor or vendor as a result of such direction by the College, the Contractor may request the United States to enter into such litigation to protect the interests of the United States.

11.4. COMPLIANCE WITH THE IMMIGRATION REFORM AND CONTROL ACT OF 1986

11.4.1. The Contractor warrants that both the Contractor and/or any subcontractor of the Contractor do not and shall not hire, recruit or refer for a fee, for employment under this Agreement or any subcontract, an alien knowing the alien is an unauthorized alien and hire any individual without complying with the requirements of the Immigration Reform and Control Act of 1986 (hereinafter referred to as "IRCA"), including but not limited to any verification and record keeping requirements. The Contractor agrees to indemnify and save the College, its employees and/or trustees harmless from any loss, costs, damages or other expenses suffered or incurred by the College, its employees and/or trustees by reason of the Contractor's or any subcontractor of the Contractor's noncompliance with "IRCA." The Contractor agrees to defend the College, its employees and/or trustees in any proceeding, action or suit brought against the College, including but not limited to administrative and judicial proceedings, arising out of or alleging noncompliance of the Contractor with "IRCA." The Contractor recognizes that it is the Contractor's responsibility to ensure that all certifications and verifications as required by law are obtained and maintained for the applicable time period.

11.5. ASSURANCE OF NONCONVICTION OF BRIBERY

11.5.1. The Contractor hereby declares and affirms that, to its best knowledge, none of its officers, directors or partners and none of its employees directly involved in obtaining contracts has been convicted of bribery, attempted bribery or conspiracy to bribe under the laws of any state or the Federal Government.

11.6. CONFLICT OF INTEREST

11.6.1. No employee of the College or of the State of Maryland, or any department, commission, agency or branch thereof whose duties as such employee include matters relating to or affecting the subject matter of this Agreement shall, until such time as the Contractor receives final payment, become or be an employee of the party or parties hereby contracting with the College, the State of Maryland, or any department, commission, agency or branch thereof.

11.7. ASSIGNMENT AND SUBCONTRACTING

11.7.1. Neither the College nor the Contractor shall sell, transfer, assign or otherwise dispose of this Agreement or any portion thereof, or its right, title or interest therein, or its obligations there under, without the written consent of the other. A change in membership of the Contractor's firm of one or more officers shall not constitute an assignment.

11.7.2. The Contractor shall not make any contracts for professional services with any other party for furnishing any of the work or services to be performed under this Agreement without the written approval of the College; however, this provision shall not be taken as requiring the approval of the contract of employment between the Contractor and its personnel assigned for the purposes of performing this Agreement.

11.8. CONTINGENT FEES

11.8.1. The Contractor hereby declares and affirms that neither it nor any of its representatives has employed or retained any person, partnership, corporation, or other entity, other than a bona fide employee or agent working for the Contractor, to solicit or secure this Agreement, and that it has not paid or agreed to pay any person, partnership, corporation, or other entity, other than a bona fide employee or agent, any fee or any other consideration contingent on the making of this Agreement.

11.9. MARYLAND PUBLIC INFORMATION ACT

11.9.1. The College is subject to the Maryland Public Information Act, Title 10 of the State Government Article of the Annotated Code of Maryland. Contractor agrees that it will provide any justification as to why any material, in whole or in part, is deemed to be confidential, proprietary information or secrets and provide any justification of why such materials should not be disclosed pursuant to the Maryland Public Information Act.

11.10. TESTING AND INSPECTION

11.10.1. The College may retain the services of testing/inspection laboratories/firms to perform the tests and make the required inspections and reports during the course of the Work as specified in the various sections of the Specifications or as required by the College in case of questions as to the strength or suitability of materials. However, for the purpose of preparing and testing design concrete mixes, the Contractor will retain the services of a testing laboratory which shall be other than that retained by the College. The Contractor shall also be responsible for all tests as indicated in the Specifications.

11.10.2. Testing/inspection laboratories/firms shall be responsible for conducting and interpreting the tests, shall state in each report whether or not the specimens tested conform to all requirements of the Contract Documents and shall specifically note deviations, if any, from said requirements. All testing/inspection laboratories/firms shall be subject to the College's approval.

11.10.3. The cost of testing services required solely for the convenience of the Contractor in its scheduling and performance of the Work, and the cost of testing services related to remedial operations performed to correct deficiencies in the Work shall be borne by the Contractor.

11.10.4. The Contractor shall furnish to the College's Representative and/or Construction Manager samples of all materials and component parts of the Work required as test specimens in connection with the specified tests, and shall furnish labor and facilities at the site as necessary in connection with testing and inspection services whether such services are performed at the expense of the College or the Contractor.

11.10.5. The nature and scope of testing services performed by an agency retained by the Contractor shall be in accordance with requirements of governing authorities having jurisdiction over the Work and as otherwise specified, and shall be consistent with reasonable standards of engineering practice.

11.10.6. If, in the performance of any testing, control, balancing, adjusting or similar activities to be performed by the Contractor or an agent of the Contractor, it is the opinion of the College's Representative and/or Construction Manager that the Contractor or said agent has failed to substantiate its ability to perform such work, the Contractor shall, at its expense, retain the services of a testing laboratory or service organization which is satisfactory to the College's Representative and/or

Construction Manager for the performance of such work.

11.11. NO WAIVER OF RIGHTS – COLLEGE'S REMEDIES CUMULATIVE – COLLEGE'S DAMAGES

11.11.1. The College shall not be precluded or estopped by any measurement, estimate, change order, contract modification, certificate of payment, or payment from showing the true amount and character of the Work furnished by the Contractor, or from showing that any measurement, estimate, change order, contract modification, certificate of payment, or payment is untrue or was incorrectly made, or from showing that the Work does not in fact conform to the Contract. The College may recover from the Contractor or its sureties, or both, such damages, loss or additional expense incurred as a result of any such error or measurement, estimate, change order, contract modification, certificate of payment, or payment as a result of such failure to conform to the Contract. The College's right in this respect shall not be waived or barred by any inspection, acceptance or approval of the Work, or by payment therefore, or by granting an extension of time, or by taking possession, or by execution of a change order based on the erroneous measurement, estimate, or change order, contract modification, certificate of payment or payment.

11.11.2. The activities of the College's Representative and/or Construction Manager, Architect/Engineer and the College respecting this Contract, including inspection of the Work, review of submittals, monitoring of progress, and so forth, are for the benefit of the College only and are not for the benefit of the Contractor. The College's failure to bring to the attention of the Contractor deficiencies in the Work or the Contractor's performance will not constitute waiver or excuse of the Contractor's failure to comply strictly with contract requirements.

11.11.3. The waiver by the College of any breach of contract by the Contractor shall not operate as a waiver of any other or subsequent breach.

11.11.4. The rights and remedies of the College and the obligations of the Contractor under various provisions of the Contract Documents and under provisions of the law are cumulative and not exclusive.

11.11.5. For any claim or cause of action accruing to the College as a result of or arising out of this Contract, the College may collect damages of any kind, including consequential damages, or damages for purely economic loss.

ARTICLE 12 – TERMINATION OF THE CONTRACT

12.1. TERMINATION FOR DEFAULT

12.1.1. The performance of the work or services under this Agreement may be terminated by the College, in whole or in part, from time to time, effective upon receipt of notice, whenever the Contractor shall default in the performance of this Agreement and fails to make progress in the prosecution of the contract work or endangers such performance and shall fail to cure such default within ten (10) calendar days period after receipt of written notification from the College specifying the default.

12.1.2. The College may terminate the Contract if the Contractor;

12.1.2.1. persistently or repeatedly refuses or fails to supply enough properly skilled Workers or materials;

12.1.2.2. fails to make payment to Subcontractors for materials or labor in accordance with their respective agreements between the Contractor and the Subcontractors;

12.1.2.3. persistently disregards laws, ordinances, or rules, regulations or orders of a public

authority having jurisdiction;

12.1.2.4. refuses or fails to prosecute the Work, or any separable part thereof with such diligence as shall ensure its completion within the time specified in the Contract or in the extension thereof;

12.1.2.5. fails to complete the Work within the time allotted by the Contract; or

12.1.2.6. is in breach of any material obligation of the Contract, including a breach which may occur after substantial completion.

12.1.3. If any of the above reasons exist, the College may without prejudice to any other rights or remedies of the College and after giving the Contractor and the Contractor's surety, if any, seven days written notice, terminate the employment of the Contractor and may, subject to any rights of the surety:

12.1.3.1. take possession of the site and all materials, equipment, tools, and construction equipment and machinery owned by the Contractor; and

12.1.3.2. finish the Work by whatever reasonable method the College may deem expedient.

12.1.4. When the College terminates the Contract for one of the reasons stated herein, the Contractor shall not be entitled to receive any further payment until the Work is finished. If the unpaid balance of the Contract Sum exceeds the cost to finish the Work, such excess shall be applied to the Contractor's unreimbursed costs, if any, accrued from the last payment prior to termination to time of termination. This amount shall become due to the Contractor. Any unreimbursed costs exceeding the difference of unpaid balance of the Contract Sum and the cost to finish the Work shall be lost to the Contractor. If the cost to finish the work exceeds the Contract Sum, the Contractor shall pay the difference to the College. The amount to be paid to the Contractor or College, as the case may be, shall survive termination of the Contract.

12.2. TERMINATION FOR CONVENIENCE

12.2.1. The College may, at any time, terminate the Contract in whole or in part for the College's convenience and without cause.

12.2.2. Upon receipt of written notice from the College of such termination for the College's convenience, the Contractor shall (1) cease operations as directed by the College in the notice; (2) take actions necessary, or that the College may direct, for the protection and preservation of the Work; and (3) except for Work directed to be performed prior to the effective date of termination stated in the notice, terminate all existing subcontracts and purchase orders and enter into no further subcontracts and purchase orders.

12.2.3. In the case of such termination for the College's convenience, the Contractor shall be entitled to receive payment from the College for all expenses incurred by it for satisfactory work, including reasonable termination expenses. Upon satisfactory proof that the Contractor would have earned a profit for Work performed prior to the date of termination, the Contractor shall be paid a reasonable amount for profit not to exceed 10% of the Contractor's costs incurred. Under no circumstances shall the Contractor be entitled to payment for anticipated but unearned profit and damages. In no event shall the Contractor's cost of the Work and profit, if any, to be reimbursed exceed the Contract Sum as adjusted by approved change orders.

END OF GENERAL CONDITIONS

This Page is Intentionally Left Blank



This Page is Intentionally Left Blank

TABLE OF CONTENTS

SPECIFICATIONS

Division 01000 General Requirements

Section

01010	Summary of Work
01040	Project Coordination
01310	Construction Schedule
01400	Quality Control System
01500	Construction Facilities/Temporary Controls
01701	Contract Closeout
01710	Cleaning
01720	Project Record Documents
01750	Warranties

Division 02000 Site Work

Section

02050	Roof Demolition
02486	Lawn Repair

Division 06000 Wood and Plastics

Section

06100	Rough Carpentry
-------	-----------------

Division 07000 Thermal and Moisture Protection

Section

07535	Steep Slope Tile Roofing
07620	Roof Related Sheet Metal
07920	Sealant and Caulking

Exhibit E Warranty

DETAIL DRAWINGS 1-4

ROOF PLAN RP-1

This Page is Intentionally Left Blank

PART ONE - GENERAL

1.1 Description

- A. This section is intended for the Contractor's general information only and is not intended to be a complete list of the work intended for this project,
- B. The scope of work is indicated on the drawings and by the requirements of each technical specification section,
- C. Project Overview
 - 1. Remove the existing clay tile shingles, felts and step/counterflashings to facilitate installation of temporary roofing as shown on the drawings at roof areas designated on the roof plan. Install new plywood underlayment atop the existing gypsum plank deck; install new WP-300HT over the entire roof surface as specified complete with required accessories.

1.2 General

- A. Products are specified in each of the technical specification sections and on the detail drawings.

PART TWO – PRODUCTS

- Not used -

PART THREE - EXECUTION

3.1 General Roof Demolition and Preparation

- A. Remove the existing clay tile roof system down to the existing roof deck and properly dispose of debris off the job site
- B. Remove the existing sheet metal flashing, and properly dispose of off of the job site.
- C. Remove existing deteriorated wood blocking or plywood decking and properly dispose of off of the job site.

3.2 Decking

- A. Remove and replace all deteriorated existing gypsum plank roof decking. New decking and installation to match existing. This work to be performed on a unit price basis. Allow for the replacement of 400 square feet to be included in the base bid amount and provide an add/deduct for amounts greater than or less than the base bid amount.

3.3 Rough Carpentry

- A. Install new treated wood blocking and plywood underlayment where required and as illustrated on the project drawings as part of the base bid.
- B. New wood blocking and plywood underlayment shall be installed in accordance with the requirements of section 06100 Rough Carpentry.

3.4 Membrane Underlayment

- A. Over the prepared roof deck, and as shown on the drawings fully adhere one ply of WP-300HT shield as specified and shown on the drawings.

3.5 Roof Related Sheet Metal

- A. N/A
- B. Install all sheet metal flashing as shown on the drawings and as specified in section 07620 Roof Related Sheet Metal.

3.7 Downspouts.

- A. Ensure that all existing roof downspouts are free from blockage and completely functional. Clean out downspouts if necessary.

3.8 Miscellaneous

- A. Install sealant where required in accordance with Section 07920 Sealant and Caulking.
- B. Installed roof system shall be warranted by the installing contractor for a period of six (6) months.

3.9 Unit Pricing

A. The following may be included in the scope of work and will be performed at unit prices.

1. Replace deteriorated existing gypsum plank decking.

- END OF SECTION -

This Page is Intentionally Left Blank

PART ONE - GENERAL

1.1 General

- A. This Section specifies requirements for project coordination including:
1. Coordination.
 2. Administrative and supervisory personnel.
 3. General installation provisions.
 4. Cleaning and protection.
- B. Coordination: Coordinate activities included in various Sections to assure efficient and orderly installation of each component. Coordinate operations included under different Sections that are dependent on each other for proper installation and operation.
1. Where installation of one component depends on installation of other components before or after its own installation, schedule activities in the sequence required to obtain the best results.
 2. Where space is limited, coordinate installation of different components to assure maximum accessibility for maintenance, service and repair.
 3. Make provisions to accommodate items scheduled for later installation.
- C. Prepare memoranda for distribution to each party involved outlining required coordination procedures. Include required notices, reports, and attendance at meetings.
1. Prepare similar memoranda for the Owner and separate Contractors where coordination of their Work is required.
- D. Administrative Procedures: Coordinate scheduling and timing of administrative procedures with other activities to avoid conflicts and ensure orderly progress. Such activities include:
1. Preparation of schedules.
 2. Installation and removal of temporary facilities.
 3. Delivery and processing of submittals.
 4. Progress meetings.
 5. Project closeout activities.

SECTION 01040
PROJECT COORDINATION

- E. Coordination Drawings: Prepare Coordination Drawings where close coordination is required for installation of products and materials fabricated off-site by separate entities, and where limited space necessitates maximum utilization of space for efficient installation of different components.
 - 1. Show relationship of components shown on separate Shop Drawings.
 - 2. Indicate required installation sequences.

- F. Staff Names: Within 5 days of Notice to Proceed, submit a list of Contractor's staff assignments, including Superintendent and personnel at the site; identify individuals, their duties and responsibilities, addresses and telephone numbers.
 - 1. Post copies in the Project meeting room, the field office, and at each temporary telephone.

- G. Inspection of Conditions: The Installer of each component shall inspect the substrate and conditions under which work is performed. Do not proceed until unsatisfactory conditions have been corrected.

- H. Manufacturer's Instructions: Comply with manufacturer's installation instructions and recommendations, to the extent that they are more stringent than requirements in Contract Documents.

- I. Inspect material immediately upon delivery and again prior to installation. Reject damaged and defective items.

- J. Recheck measurements and dimensions, before starting installation.

- K. Install each component during weather conditions and project status that will ensure the best results. Isolate each part from incompatible material as necessary to prevent deterioration.

- L. Cleaning and Protection: During handling and installation, clean and protect construction in progress and adjoining materials in place. Apply protective covering where required to ensure protection from damage or deterioration at Substantial Completion.
 - 1. Clean and maintain completed construction as often as necessary through the construction period. Adjust and lubricate operable components to ensure operability without damaging effects.
 - 2. Limiting Exposures: Supervise operations to ensure that no part of construction, completed or in progress, is subject to harmful or deleterious exposure. Such exposures include:
 - a. Excessive weathering.

- b. Excessively high or low temperatures or humidity.
- c. Air contamination or pollution.
- d. Water or ice.
- e. Chemicals or solvents.
- f. Heavy traffic, soiling, staining and corrosion.
- g. Rodent and insect infestation.
- h. Unusual wear or other misuse.
- i. Contact between incompatible materials.
- j. Theft or vandalism.

PART TWO - PRODUCTS

- Not Used -

PART THREE - EXECUTION

- Not Used -

- END OF SECTION -

This Page is Intentionally Left Blank

PART ONE - GENERAL

1.1 Description

A. Work Included

1. To assure adequate planning and execution of the work so the work is completed within the number of calendar days allowed in the contract, and to assist the owner in evaluating progress of the work, prepare and maintain the schedules and reports described in this section.

B. Definitions

1. "Day" used throughout the contract, unless otherwise stated means "calendar day."

1.2 Reliance Upon Approved Schedule

- A. Should any activity not be completed within fifteen days after the stated scheduled date, the owner shall have the right to order the contractor to expedite completion of the activity by whatever means the owner deems appropriate and necessary, without additional compensation to the contractor.
- B. Should any activity be 30 or more days behind schedule, the owner shall have the right to perform the activity or have the activity performed by whatever method the owner deems appropriate.
- C. Costs incurred by the owner in connection with expediting construction activity under this article shall be reimbursed to owner by the contractor.
- D. It is expressly understood and agreed that failure by the owner to exercise the option to either order the contractor to expedite an activity or to expedite the activity by other means shall not be considered precedent setting for any other activities.

1.3 Submittals

A. General

1. Comply with the provisions of Section 01300.

B. Construction Schedule

1. Submit two prints of construction schedule prepared in accordance with Part Three of this section.

PART TWO - PRODUCTS

2.1 Construction Analysis

A. Diagram

1. Legibly in either a typed or ink format, graphically show the order and interdependence of all activities necessary to complete the work, and the sequence in which each activity is to be accomplished, as planned by the contractor and his project field superintendent in coordination with all subcontractors whose work is shown on the diagram.
2. The detail of information shall be such that duration times of activities shall be more than one day. The selection and number of activities shall be subject to the owner's approval.

PART THREE - EXECUTION

3.1 Construction Schedule

- A. At the pre-construction meeting, present the completed construction schedule.

3.2 Periodic Reports

- A. On the first working day of each month or with each payment request, submit two prints of the construction schedule updated as described below.

3.3 Construction Schedule

- A. Show activities or portions of activities completed during the reporting period.
- B. State the percentage of work actually completed and schedule as of the report date, and the progress in terms of days ahead or behind the allowable dates.
- C. If work is behind schedule, a narrative report which describes, but is not necessarily limited to:
1. A description of the problem areas, current and anticipated;
 2. Delaying factors and their impact;
 3. An explanation of corrective actions taken or proposed.
- D. Contractor may not remove the roofing crew from the project site until all work has been reviewed and certified substantially complete in writing by the consultant or by

SECTION 01310
CONSTRUCTION SCHEDULE

the owner. Should the contractor remove the subject crew without prior approval or weather related causes, liquidated damages shall apply.

- END OF SECTION -

This Page is Intentionally Left Blank

PART ONE - GENERAL

1.1 General Requirements

- A. The contractor shall establish and maintain throughout the life of the contract the quality control system as specified herein (referred to in this Section as the "System").
- B. Requirements: The System shall provide for the performance of sufficient inspection and tests of all items of work, including the work of subcontractors, to ensure the conformance to the applicable specifications and drawings with respect to materials, workmanship, construction, finish, functional performance and identification. The System shall specifically include the surveillance and tests required by the technical provisions of the specifications.

1.2 Operations

- A. Inspection: The System shall be designed to cover all construction operations, including both on-site fabrication, and shall be keyed to the proposed construction sequence. The System shall include at least three phases of inspection for all definable features of work, as follows:
- B. Preparatory Inspection shall be performed prior to beginning performance of any definable feature of work and shall include: a review of the applicable requirements of this contract; a check to assure that all materials and/or equipment have been tested, submitted, and approved in accordance with such requirements; a check to assure that provisions have been made to provide required control testing; examination of the work area to ascertain that all materials and/or equipment are on hand. The Owner shall be notified at least 24 hours in advance of the preparatory inspection.
- C. Initial Inspection shall be performed as soon as a representative portion of the particular feature of work has been accomplished and shall include examination of the quality of workmanship and a review of control testing for compliance with contract requirements, use of defective or damaged materials, omissions, and dimensional requirements. The Owner shall be notified at least 24 hours in advance of the initial inspection.
- D. Follow-up Inspections shall be performed daily to assure continuing compliance with the requirements of this contract, including control testing until completion of the particular feature of work.
- E. All such inspection shall be made a matter of record in the contractor's quality control documentation.
- F. Record and Submittals

SECTION 01400
QUALITY CONTROL SYSTEM

1. The contractor shall maintain current records of inspections and tests performed. These records shall include factual evidence that the required inspections or tests have been performed, including the type and number of inspections or tests involved; the results of inspections or tests; the nature of defects, causes for rejection and similar data; the proposed remedial action; and any corrective action taken. The contract shall not build upon or conceal any feature of the work containing uncorrected defects. These records shall cover both conforming and defective or deficient features and shall include a statement that all supplies and materials incorporated in the work are in full compliance with the terms of this contract. Legible copies of these records shall be furnished to the Owner daily. The records shall cover all work placement subsequent to the previously furnished records and shall be verified by the contractor. The contractor shall document inspection and tests as specified in each technical section of the specifications, and these records shall be available for review by the Owner throughout the term of this contract. In addition, the contractor's quality control reports shall include a statement that material and equipment received at the site are properly stored for protection from the elements and construction activities.

2. The contractor shall submit to the Owner, no less 10 days prior to beginning performance of the work, a written statement of the System proposed to be established pursuant to this clause, including:
 - a. Detailed descriptions of all testing, inspection, and other quality control methods and procedures to be used by the contractor;
 - b. Quality control facilities and equipment to be provided;
 - c. Personnel to be assigned by the contractor to implement the System including a full-time chief of quality control and their respective qualifications, responsibilities and functions; and
 - d. All forms and other documentation to be used by the contractor in the implementation and administration of the System. The contractor shall not begin performance of any portion of the work until the proposed System (including all elements thereof listed in subparagraphs a through d above) with such modifications as the Owner may require, has been approved in writing by the Owner.

3. The Owner may direct the contractor at any time to make such changes in the System, including changes in personnel, as the Owner deems necessary or desirable to correct any inadequacies or deficiencies, and the contractor shall comply promptly with any such direction.

PART TWO - PRODUCTS

- Not Used -

PART THREE - EXECUTION

- Not Used -

- END OF SECTION-

This Page is Intentionally Left Blank

PART ONE - GENERAL

1.1 Description

A. Work Included

B. Temporary facilities and controls required for this work include, but are not necessarily limited to:

1. Temporary utilities such as heat, water, and electricity.
2. Contractor's and sanitary facilities.
3. Enclosures such as tarpaulins, barricades and canopies.

C. Related work described elsewhere:

1. Except that all equipment furnished by subcontractors shall comply with all requirements of pertinent safety regulations, the ladders, planks, hoists, and similar items normally furnished by the individual trades in execution of their own portions of the work are not part of this section.
2. Permanent installation and hookup of the various utility lines are described in the pertinent other sections of these specifications.

1.2 Product Handling

A. Use all means necessary to maintain temporary facilities and controls in proper and safe condition throughout progress of the work.

1.3. Job Conditions

A. Make all required connections to existing utility systems with minimum disruption to services in the existing utility systems. When disruption of the existing service is required, do not proceed without the owner's approval and, when required, provide alternate temporary service.

PART TWO - PRODUCTS

2.1 Utilities

A. General: All temporary facilities shall be subject to the owner's approval.

2.2 Electrical Facilities

SECTION 01500
CONSTRUCTION FACILITIES
AND TEMPORARY CONTROLS

- A. The contractor shall make arrangements with the owner to connect into the existing electrical service for temporary power. Contractor shall furnish and install all temporary wiring and upon completion of the work, remove such temporary facility. If electrical power is not available by owner, Contractor shall provide temporary power.
- B. Unless otherwise designated by the owner, the circuit provided for the contractors use shall be limited to 110 volts for the operation of hand power tools and small machines. Motors are not to exceed 3/4 HP per unit of equipment.
- C. Runs of the temporary power lines to the construction area shall not pass through areas of the facility open to the patrons of the owner. These lines shall have adequate safety protection against harm to personnel and property.

2.3 HVAC

- A. Disconnecting and reconnecting of mechanical units during the construction phase will be the owner's responsibility. This shall be coordinated between Contractor and the Owner with Contractor giving a minimum of (48 hours) notice prior to the shutdown of mechanical systems during the construction period.

2.4 Water Facilities

- A. The owner shall designate a source for construction water and shall pay the cost of water used for construction purposes.
- B. The contractor shall provide temporary connections to the water source and all piping, fittings, and hoses required to extend the water supply to the work area, and remove same at the completion of the project.

2.5 Sanitary Facilities

- A. Provide temporary sanitary facilities in the quantity required, for use of all personnel. Maintain in a sanitary condition at all times.
- B. Locate temporary sanitary facilities in the area designated by the owner.

SECTION 01500
CONSTRUCTION FACILITIES
AND TEMPORARY CONTROLS

2.6 Enclosures

- A. Furnish, install, and maintain for the duration of the project all required scaffolds, tarpaulins, barricades, warning signs, steps, ramps, bridges, platforms, and other temporary construction necessary for proper completion of the work in compliance with all safety regulations and local codes.
- B. Contractor is responsible for the structural integrity of all temporary construction. Temporary construction shall meet all pertinent safety regulations.

2.7 Fencing of the Construction Area

- A. Furnish and install temporary barricades as directed by owner around ground located equipment and materials.

PART THREE - EXECUTION

3.1 Material and Removal

- A. Maintain all temporary facilities and controls as long as needed for the safe and proper completion of the work. Remove all such temporary facilities and controls as rapidly as progress of the work will permit, or as directed by the consultant.

- END OF SECTION -

This Page is Intentionally Left Blank

PART ONE - GENERAL

1.1 Description

A. Work Included

B. Submit all forms required by this section to document the completion of the project.

C. Related Requirements Specified Elsewhere:

1. Completion: Waiver of Claims: General Conditions.
2. Cleaning: Section 01710.
3. Project Record Documents: Section 01720.
4. Warranties: Section 01750.
5. Closeout submittals required for trades: Respective Sections of specifications.
6. Substantial completion: Conditions of the contract.
7. Final Payment: General Conditions.

PART TWO- PRODUCTS

2.1 Forms: Documentation shall be made on forms provided by the Owner's Representative.

PART THREE- EXECUTION

3.1 Substantial Completion

A. Contractors:

1. Submit written certification to the Owner through the Owners Representative, that project, or designated portion of project, is substantially complete.
2. Submit list of major items to be completed or corrected.

B. Owner and Owners Representative will make an inspection after receipt of certification.

C. Should owner and Owners Representative consider that work is substantially complete:

SECTION 01701
CONTRACT CLOSEOUT

1. Contractor shall prepare and submit to Owner through the Owners Representative, a list of all items to be completed or corrected, as determined by the inspection.
 2. Owners Representative will prepare and issue a certificate of substantial completion, containing:
 - a) Date of substantial completion.
 - b) Contractor's list of items to be completed, verified and amended by Owner and Owners Representative.
 - c) The time within which contractor shall complete or correct work of listed items.
 - d) Time and date Owner will assume possession of work or designated portion thereof.
 3. Contractor: Complete work listed for completion or correction, within designated time.
- D. Should Owner and Owners Representative consider that work is not substantially complete:
1. The Owners Representative shall immediately notify contractor, in writing, stating reasons.
 2. Contractor: Complete work, and send second written notice to Owner, certifying that project, or designated portion of project, is substantially complete.
 3. Owner and Owners Representative will re-inspect work.

3.2 Final Inspection:

- A. Contractor shall submit written certification that:
1. Contract documents have been reviewed.
 2. Project has been inspected for compliance with contract documents.
 3. Work has been completed in accordance with contract documents.
 4. Project is completed and ready for final inspection.

SECTION 01701
CONTRACT CLOSEOUT

- B. Contractor shall indicate, with notice of completion to manufacturer, that a 50 year Gold Star, labor-and-material warranty is required for this project and is to be signed and sent to the contractor.
- C. Owner and Owners Representative will make final inspection after receipt of certification.
- D. Should Owner and Owners Representative consider that the work is finally complete in accordance with requirements of contract documents, Owners Representative shall request contractor provide project closeout submittals.
- E. Should Owner and Owners Representative consider that work is not finally complete:
 - 1. Owners Representative shall notify contractor, in writing, stating reasons.
 - 2. Contractor shall take immediate steps to remedy the stated deficiencies, and send second written notice to Owner certifying that work is complete.
 - 3. Owner Owners Representative and will re-inspect work.

3.3 Re-inspection Costs

- A. Should owner and Owners Representative be required to perform second inspections (or more) because of failure of work to comply with original certifications of contractor, contractor will compensate owner and Owners Representative for additional services and expenses. Owner will deduct the compensation from the final payment to contractor.

3.4 Closeout Submittals

- A. Project Record Documents: As required by Section 01720.
- B. Warranties: As required by Section 01750.
- C. Evidence of Payment and Release of Liens.
- D. Contractor's Affidavit of Payment of Debts and Claims: AIA G706.
- E. All submittals shall be duly executed before delivery to owner through the Owners Representative.

3.5 Final Adjustment of Accounts

- A. Submit final statement of accounting to Owner through the Owners Representative.
- B. Final statement shall reflect all adjustments, including:

1. Original contract sum.
2. Additions and deductions resulting from (if applicable):
 - a) Previous change orders.
 - b) Cash allowances.
 - c) Unit prices.
 - d) Other adjustments.
 - e) Deductions for uncorrected work.
 - f) Deductions for re-inspection payments.
3. Total contract sum, as adjusted.
4. Previous payments.
5. Sum remaining due.

C. Owner will prepare final change order, reflecting approved adjustment to contract sum not previously made by change orders.

3.6 Final Application for Payment

A. Contractor shall submit final application in accordance with conditions of the contract.

3.7 Final Certificate for Payment

A. The owner will issue final certificate in accordance with provisions of general conditions.

- END OF SECTION -

PART ONE - GENERAL

1.1 Description

A. Work Included

1. Throughout the construction period, maintain the buildings and site in a standard of cleanliness as described in this Section.

B. Related Work Described Elsewhere

1. In addition to standards described in this Section, comply with all requirements for cleaning as described in various other Sections of these specifications.

1.2 Quality Assurance

- A. Conduct daily inspection, and more often if necessary, to verify that requirements of cleanliness are being met.

PART TWO- PRODUCTS

2.1 Cleaning Materials and Equipment

- A. Provide all required personnel, equipment, and materials needed to maintain the specified standard of cleanliness.

2.2 Compatibility

- A. Use only the cleaning materials and equipment which are compatible with the surface being cleaned, as recommended by the manufacturer of the material or as approved by the Owner.

PART THREE - EXECUTION

3.1 Progress Cleaning

A. Material Storage

1. Retain all stored items in an orderly arrangement allowing maximum access, not impeding drainage or traffic, and providing the protection required to maintain the materials in an undamaged condition.

B. General

SECTION 01710
CLEANING

1. Do not allow the accumulation of scrap, debris, waste material, and other items not required for construction of this work.
2. At least once each week and more often if necessary, completely remove all scrap, debris, and waste material from the job site.
3. Provide adequate storage for all items awaiting removal from the job site, observing all requirements for fire protection and protection of the surrounding site.

C. Site

1. Daily, and more often if necessary, inspect the site and pick up all scrap, debris, and waste material. Remove all such items to the place designated for their storage.
2. Weekly, and more often if necessary, inspect all arrangements of materials stored on the site, restack, tidy, or otherwise service all arrangements to meet the requirements of subparagraph 3.1.1 above.
3. Maintain the site in a neat and orderly condition at all times.

3.2 Final Cleaning

A. Definition

1. Except as otherwise specifically provided, "clean" (for the purpose of this article) shall be interpreted as meaning the level of cleanliness generally provided by skilled cleaners using commercial quality building maintenance equipment and materials.

B. General

1. Prior to completion of the work, remove from the job site all tools, surplus materials, equipment, scrap, debris, and waste. Conduct final progress cleaning as described in article 3.1 above.

C. Site

1. Unless otherwise specifically directed by the Owner, clean all adjacent areas on the site. Completely remove all resultant debris.

D. Building Interior

SECTION 01710
CLEANING

1. Where owner has allowed contractor access through the building interior, visually inspect all access routes and remove all traces of soil, smudges, and other foreign matter. Any materials damaged as a result of this project shall be repaired to the satisfaction of the owner or replaced at no additional cost to the owner.

E. Building Exterior

1. Visually inspect all exterior surfaces and remove all traces of soil, waste material, smudges, and other foreign matter. Remove all traces of splashed materials from adjacent surfaces. If necessary to achieve a uniform degree of exterior cleanliness, hose down the exterior of the structure. In the event of stubborn stains not removable with water, the Owner may require light sandblasting or other cleaning at no additional cost to the owner.

- END OF SECTION -

This Page is Intentionally Left Blank

PART ONE - GENERAL

1.1 Description

- A. Throughout the work of this contract, maintain an accurate record of the following:
 - 1. Contract documents (project manual with shop drawings).
 - 2. Addendum.
 - 3. Change orders and other modifications to the contract.
 - 4. Field orders and instructions.
 - 5. Construction schedule.
 - 6. Product samples.
 - 7. Shop drawings.
 - 8. Progress reports.

1.2 Quality Assurance

- A. Delegate the responsibility for maintenance of record documents to one person on the contractor's staff as approved in advance by the Owner.
- B. Make all entries within 24 hours after receipt of information.

1.3 Submittals

- A. Prior to submitting each request for progress payment, secure the Owner's Representatives approval of the record documents as currently maintained.
- B. Prior to submitting request for final payment, submit the final record documents to the Owner's Representative and secure his approval.

1.4 Product Handling

- A. Use all means necessary to maintain the job set of record documents completely protected from deterioration and from loss and damage until completion of the work and transfer of the recorded data to the final record documents.

PART TWO - PRODUCTS

2.1 Record Documents

- A. Secure from the Owner at the pre-construction meeting, at no charge to the contractor, one complete set of all documents comprising the contract.

PART THREE - EXECUTION

3.1 Maintenance of Record Documents

- A. Upon receipt of record documents described in paragraph 2.1 above, identify each of the documents with the title "Project Record Documents".
- B. Maintain the record documents at the job site. Documents to be available to the owner and Owner's Representative during all working hours.
- C. The contractor shall use record document set to record day by day "as built" information. Where the drawings are diagrammatic, such drawings shall be corrected or redrawn to show actual installation.
- D. During the phase of construction, if required by the Owner's Representative, contractor shall obtain a set of prints from the Owner's Representative without cost and shall, in a neat and legible manner, transfer an "as built" information from the record set.

3.2 Review and Approval

- A. Submit the completed total set of record documents to the Owner's Representative for review. Participate in review meeting or meetings as required by the Owner's Representative, make all required changes in the documents and promptly deliver the final project record documents through the Owner's Representative to the owner.

- END OF SECTION -

PART ONE - GENERAL

1.1 Description

- A. The following items are to be submitted to the Owners Representative as part of this Section.
- B. Copies of all manufacturer's punch lists and documentation of completion.
- C. Copies of all Owners Representative punch lists and documents of completion.
- D. Manufacturer's report that roof has been inspected and is suitable for warranty.
- E. Contractor's written six month guarantee covering all materials and workmanship form follows bid form of these specifications.

1.2 Related work described elsewhere.

- A. For additional project close-out documentation, see Section 01701.

PART TWO - PRODUCTS

2.1 Format

- A. All required documentation shall be in a format approved by the Owner.

PART THREE - EXECUTION

3.1 Submit all required documentation upon completion of the work and prior to final payment.

3.2 All warranties are to be submitted to the Owner, through the Owners Representative.

- END OF SECTION -

This Page is Intentionally Left Blank

PART ONE- GENERAL

1.1 Description

- A. Provide all labor, material, equipment, and tools as required to prepare the existing roofing system for re-roofing as specified in this Section.
- B. Provide for the proper disposal of all existing materials designated to be removed. Use approved trash receptacles in areas designated by the owner's representative.
- C. Coordinate the roof preparation work with the new roofing work in such a manner as to keep the new insulation and roofing materials, building, and building interior absolutely clean, dry and watertight.

PART TWO - PRODUCTS

- Not Used -

PART THREE - EXECUTION

3.1 Protection of Surfaces

- A. Contractor shall take all necessary precautions during roof preparation to protect the building and adjacent surfaces from being soiled or damaged and from roof top debris filtering down through the roof deck into the buildings interior.
- B. When weather threatens, cease work under this section and return roof to a watertight condition.
- C. Contractor shall restore to original condition any damages caused during work performed in this Section.
- D. Return all roof drainage components to operating condition at the end of each working day.

3.2 Disposal

- A. Thoroughly clean and remove all debris from the deck surface and any joints in the roof deck which may exist.
- B. Properly dispose of all debris from roof preparation on a daily basis.
- C. Do not store debris on roof. Contractor shall take care not to over stress roof deck.

SECTION 02050
ROOF DEMOLITION

D. Provide closed trash chutes or other approved means for removal of debris.

3.3 Preparation of surfaces.

A. Remove and dispose of all debris from roof surface.

B. Tear off the existing roofing down to the gypsum plank roof deck and properly dispose of all debris off site.

C. Remove debris from the supporting deck surface.

D. Remove all sheet-metal components where indicated.

E. Remove all deteriorated existing wood blocking discovered following the roof removal.

F. Remove all deteriorated roof decking discovered following the roof removal.

3.4 Clean-Up

A. Prior to the completion of the work remove from the job site all tools, equipment, debris and waste.

B. Conduct final cleaning as per Section 01710.

- END OF SECTION -

PART ONE- GENERAL

1.1 Related Documents

- A. All applicable provisions of the Bidding and Contract Requirements, and Division 1 - General Requirements shall govern the work under this Section.

1.2 Work Included

- A. Provide all labor, materials, necessary equipment and services to complete the lawn repair work, as specified herein to return the existing vegetation to pre-roofing condition.

1.3 Quality Assurance

- A. Standards: Federal Specification (FS) 0-F-241C (1), Fertilizers, Mixed, Commercial.
- B. Test Agency: Independent testing laboratory.
- C. Requirements of Regulatory Agencies: Comply with requirements of the State Department of Agriculture.
- D. Source Quality Control: Producer's tests for purity and germination of seed, dated within nine months of sowing.

1.4 Submittals

- A. Test Reports: Results of seed purity and germination tests.
- B. Certificates: Manufacturer's certification that materials meet specification requirements.

1.5 Job Conditions

- A. Existing Conditions: Perform seeding only after preceding work affecting ground surface is completed.
- B. Environmental Requirements:
 - 1. Do not perform seeding when wind exceeds 15 mph.
 - 2. Seed during months acceptable to the Landscape Architect.
- C. Protection: Restrict foot and vehicular traffic from seeded areas after planting until the end of the established period.

PART TWO - PRODUCTS

2.1 Seeds

- A. Species: Common Bermuda Grass (hulled), 95% pure; 85% minimum germination rate.
- B. Species: Kentucky 31 Tall Fescue; 98% pure; 90% germination rate.

2.2 Fertilizer

- A. FS O-F-241, Type 1, Grade A or B.
- B. The chemical designation shall be 5-10-15, with at least 50% of the nitrogen from a non-water soluble organic source.
- C. Organic fertilizer: Milorganite.

2.3 Mulch

- A. Straw mulch. Straw mulch shall conform to the following specifications. Areas to be seeded include all areas where the ground cover has been disturbed in connection with the construction. All sides, slopes, bottoms, or any other exposed surfaces shall have the full application of seed and mulch as specified herein.

2.4 Stakes

- A. Sound wood, 1" x 2" x 18".

2.5 Water

- A. Free of matter harmful to plant growth.

PART THREE - EXECUTION

3.1 Conditions

- A. Check that preceding work affecting ground surface is completed.
- B. Do not start work until conditions are satisfactory and areas to be seeded have been approved by Engineer.

3.2 Preparation

- A. Till fertilizer into top 2" of soil at a rate of 6 pounds per 2000 square feet.

- B. Water dry topsoil to depth of 6" at least 48 hours prior to seeding to obtain a loose friable seed bed.

3.3 Application

- A. Broadcast half of seed with mechanical seeder or hydroseed.
- B. Broadcast remaining half of seed at right angles to first seeding pattern, using same broadcast method.
- C. Apply seed at the following rates: Bermuda Grass - 10 pounds per acre; Kentucky 32 Tall Fescue - 100 pounds per acre.
- D. Cover seed to depth of 1/8" by raking, harrowing or cultipacking.
- E. Roll seeded area with roller weighing maximum of 150 pounds per foot of width. Make two passes.
- F. Apply organic fertilizer, milorganite, at two pounds per 1000 square feet to all seeded areas.
- G. Place mulching cloth over seeded area sloped greater than 2:1.
- H. Anchor mulching fabric with stakes 4' on center and at edges.
- I. Water seeded areas to depth of 6" immediately after seeding/rolling operations.

3.4 Protection

- A. Immediately after seeding, erect barricades and warning signs to protect seeded areas from traffic until grass is established.

3.5 Lawn Establishment

- A. Watering
 - 1. Keep soil moist during seed germination period.
- B. Reseed larger than one square feet not having uniform stand of grass.
- C. Establishment period to extend until acceptance by the Owner.

3.6 Clean Up

- A. Remove trash and excess materials from project site.
- B. Maintain period areas in clean condition.
- C. Remove barriers and signs from project site at termination of establishment period.

3.7 Final Inspection and Acceptance

- A. Request final inspection for each area as the area is completed.
- B. Reseed rejected grass area within two weeks after the inspection or as otherwise directed by the County.

- END OF SECTION -

PART ONE - GENERAL

1.1 Description

- A. Work Included: Install all treated wood nailers, plywood decking, and blocking where required for the replacement of deteriorated existing wood blocking and where indicated on the drawings to provide an acceptable substrate for the roof installation.

1.2 Related Work Described Elsewhere

A. Roofing

1. Quality Assurance

- B. Qualifications of Workmen: Provide sufficient workmen and supervisors who shall be present at all times during execution of this portion of the work and who shall be thoroughly familiar with the type of construction involved and the materials and techniques specified.
- C. Rejections: In the acceptance or rejection of rough carpentry, the owner will make no allowance for lack of skill on the part of workmen.
- D. All work shall conform to pertinent standards of factory mutual testing.
- E. Prior to commencement of roof demolition operations, contractor to perform fastener pull out tests with a calibrated testing apparatus, specified plywood to gypsum fasteners in the presence of the owner's Structural Engineer at twelve locations to be determined by the Structural Engineer.

1.3 Product Handling

A. Protection

- 1. Store all materials up, off of the roof deck or ground, and covered with a weatherproof covering anchored sufficiently so as to resist wind blow-off.
- 2. Keep all materials clearly identified with all grade marks legible. Keep all damaged material clearly identified as damaged and stored separately to prevent its inadvertent use.
- 3. Do not allow installation of damaged or otherwise non-complying material.

- B. Replacement: In the event of damage, immediately make all necessary repairs and replacements to the approval of the owner and at no additional cost to the owner.

PART TWO - PRODUCTS

2.1 Nailers and Replacement Decking

- A. All nailers and tongue & grove plywood decking shall be #2, or better, and pressure treated with a salt preservative. Wolmanized treatment is approved. Do not use asphaltic or creosote preservatives.
- B. Size for nailers to be as indicated on the drawings. Minimum size to be 1" x 6".
- C. Size for plywood decking to be as indicated on the drawings.

2.2 Fasteners

All fasteners must have corrosion-resistant coating.

A. Masonry/Concrete Fasteners

- 1. Threaded Masonry/Concrete Fasteners
- 2. Corrosion-resistant, threaded fastener with a low profile head.
- 3. Screw fastener to be factory mutual approved.
- 4. Approved Products
 - a) Confas by Construction Fasteners
 - b) Tapcon Flat Head Phillips by Buildex
 - c) Confixx by Fabco

B. Other Masonry/Concrete Fasteners

1. The following fasteners may also be used.
 - a) Metal Hit Anchor by Hilti
 - b) Rawl-Drives by Rawl
 - c) Zamac Nailin by Rawl
 - d) Gripcon by Fastenrite

C. Threaded Steel/Wood Fasteners

1. Corrosion-resistant, self-tapping, self-drilling screw with low profile head.
2. Screw type fastener to be factory mutual approved.
3. Approved Products
 - a) Dekfast by Construction Fasteners
 - b) Roof Grip by Buildex
 - c) Insul Fixx by Fabco

D. Wood to Wood Fasteners

1. Nails
 - a) Number 10, hot-dipped, galvanized steel or 304 stainless steel ring shank as minimum size.
 - b) Minimum embedment to base substrate to be 1".
2. Screws
 - a) Number 10, 300 series stainless steel wood screw or #14 Phillips Pan 300 series stainless steel sheet metal screws as minimum size.
 - b) Minimum embedment to base substrate to be 1".

E. Plywood Underlayment to Gypsum Fasteners

1. Screws
 - a) SDS ¼" x 2 ½" long as manufactured by Simpson.

PART THREE - EXECUTION

3.1 Nailers

- A. Nailers shall be installed as per detailed drawings.
- B. Nailers shall be anchored to resist a pull of 175 pounds per foot.
- C. Fasteners to be spaced a maximum of 24" on center for 2" nailers and 12" on center for all 1" nailers.
- D. Nailers shall be installed with joints true and tight.

3.2 Plywood Underlayment

- A. Adhere plywood to existing Gypsum Decking using construction adhesive. Adhesive application to be per manufacturer's published installation procedures.
- B. Pre-drill plywood and countersink fasteners ¼" at all locations to receive fasteners.
- C. Fasteners to be spaced a maximum of 12" on center horizontally and vertically in the field of the roof. Edge fasteners shall be installed 1" from the edge reducing the next spacing to 11".
- D. Fasteners to be spaced a maximum of 6" on center horizontally and vertically at roof edges. Edge fasteners shall be installed 1" from the edge reducing the next spacing to 5".
- E. Plywood shall be installed with joints true and tight.

3.3 Clean-Up

- A. Premises shall be kept in a neat and orderly condition.
- B. After installation of all rough carpentry, contractor shall remove all construction debris and equipment from job site.

- END OF SECTION -

PART ONE - GENERAL

1.01 Description

- A. Work included: Furnish and install a weather and watertight steep slope underlayment for a future EchoStar rubber tile roof system, as shown in the detail drawings and as specified herein on existing steep slope areas of the Science and Applied Studies Building as indicated on the drawing.
- B. Related Sections: Work contained elsewhere, when applicable.
 - 1. Roof Demolition
 - 2. Rough Carpentry
 - 4. Related Sheet Metal
 - 5. Sealants and Caulking

1.02 References

- A. All work under this section shall conform to the more stringent product and performance procedures outlined within the project specifications and as outlined in, recommended in or specified in the latest edition of:
 - 1. Factory Mutual System (FM)
 - a. Approval Guide
 - 2. Underwriter's Laboratory (UL)
 - a. Building Materials Directory
 - 3. American Society for Testing and Materials (ASTM)
 - a. Book of Standards
 - 4. National Roofing Contractors Association (NRCA)
 - a. Roofing and Waterproofing Manual
 - b. Handbook of Accepted Roofing Knowledge (HARK)
 - 5. Published material manufacturer's literature and specifications as submitted for approval.

1.03 System Description

- A. Roofing Underlayment Membrane System: CCW WIP 300HT by Carlisle Coatings & Waterproofing Incorporated
- B. Roofing system shall be FM Class 1 rated as well as UL Class A fire rated. Use of the existing 2" gypsum decking may be used to achieve

SECTION 07535
TEMPORARY ROOFING

roof system ratings. Use of emulsions or coating as a system surfacing shall not be used to achieve roof system ratings.

1.04 Submittals

- A. General: Comply with all provisions of the contract documents, to include any additional submittal requirement not listed herein. Requirements listed herein are the minimum acceptable.
- B. Product Data and Samples: After award of contract, submit:
 - 1. Complete material list of all items proposed to be furnished and installed under this section.
 - 2. Manufacturers complete literature and specifications for installation of the specified roof system.
 - 3. Two samples of each mechanical fastener to be used for installation of the roof system.
 - 4. Certification of FM approval of mechanical fasteners used in the work of this section.
 - 5. Manufacturer's written certification that the contractor is an approved installer of the specified roof system products submitted. Manufacturer's statement of certification shall include the date of original contractor approval.
 - 6. Two 12" x 12" samples of each sheet material to be used for the construction of the base flashing.
- C. Shop Drawings
 - 1. Manufacturer approved shop drawings shall include detailed installation of all roof system components, as listed, but not limited to:
 - a. Wood nailers and decking
 - b. Sheet metal flashing and components
 - c. Roof system field membrane
 - d. Roof system base flashing
- D. Project Record Documents

SECTION 07535
TEMPORARY ROOFING

1. Upon completion of the roof system installation, provide written certification that the roof system assembly has been installed in accordance with the project specifications and drawings, and any approved contractor submitted shop drawings.
2. As specified elsewhere, provide all required warranties, guarantees, and other such documents.

1.05 Quality Assurance

- A. Standards: Comply with the standards specified in this section and as listed in the general requirements.
- B. Qualification of Manufacturer: Products used in the work included in this section shall be produced by manufacturers regularly engaged in the manufacture of similar items and with a history of successful production acceptable to the owner.
- C. Qualifications of Contractor: The contractor and his personnel shall be currently approved by the manufacturer of the approved products as qualified to install the materials of this section.
- D. Qualifications of Installers: Use adequate numbers of skilled workmen who are thoroughly trained and experienced in the necessary crafts and who are completely familiar with the specified requirements and the methods needed for proper performance of the work in this section.
- E. Roofing Inspections: Make all required notifications and secure all required inspections by the manufacturer of the approved materials to facilitate issuance of the specified roof warranty.
- F. Rejection: In the acceptance or rejection of work under this section, no allowance will be made for lack of skill or specification understanding on the part of the workmen. It shall be incumbent upon the contractor to use adequate numbers of skilled installers and to instruct them in the requirements of the project specifications as well as maintaining a set of the project specifications and drawings on the roof at all times.
- G. Replacement: In the event inadequate or improper installation is determined, contractor shall make all repairs and replacements required to render the installation compliant with the project specifications. Replacements, due to improper performance, shall be at the sole cost of the contractor.

1.06 Product Handling, Delivery, and Storage:

SECTION 07535
TEMPORARY ROOFING

- A. Deliver all packaged materials to the job site in their original unopened containers with all labels intact and legible at the time of the inspection and in sufficient quantities to provide continuous installation progress without disruption or delay due to lack of materials on site.
- B. Store all materials in an approved manner, up off of the roof deck or ground, and protected from exposure to the elements.
- C. Store all rolls of felts, cartons and drums of cements, primers and coating on end.
- D. Protection: Use all necessary means to protect the materials in this section before, during, and after installation, and to protect the work and materials of all other trades.
- E. Replacements: In the event of damage, immediately make all repairs and replacement necessary to the approval of and at no additional cost to the owner.

1.07 Site Conditions

- A. General: Do not uncover or install material under this section during periods of inclement weather. Weather condition either current or predicted, that would prevent proper execution of the work under this section shall determine placement acceptability for each days work.
- B. Work shall not be performed under this section if the ambient temperature is below 45 degrees Fahrenheit, without prior written approval.
- C. Field Measurements: Verification of all termination points and penetration locations, dimensions, sizes and quantities are the responsibility of the contractor as outlined in the contract documents. Actual field measurements shall be used in the preparation of contractor submitted shop drawings.

1.08 Sequencing and Scheduling

- A. Verify that all preparatory and sequential prior work is complete and properly installed before performing work of this section.
- B. Phased construction is strictly prohibited. Incomplete installation of all roof system components is justification for rejection of part or all work performed as being improper installation.

1.09 Warranty

SECTION 07535
TEMPORARY ROOFING

- A. Material and installation shall meet all the requirements necessary to fulfill the warranty conditions and provisions set forth in the specification and as specifically written in the roof membrane system manufacturer's warranty as submitted.

PART TWO - PRODUCTS

2.01 General

- A. Provide products which are recommended by the manufacturer and that are fully compatible with indicated substrates and other assembly components.

2.02 Temporary Roofing membrane

- A. The installed roof system shall consist of one ply of CCW WIP 300HT by Carlisle Coatings & Waterproofing Incorporated
- B. Plastic Cement
 - 1. Trowel grade, asphaltic based flashing cement conforming to ASTM D-4586-86. (Non asbestos containing)
- C. Fasteners
 - 1. Shall be of adequate design to achieve substantial and positive anchorage into the fastening substrate.
- D. Base Sheet Fasteners
 - 1. Mechanical attachment of base ply to meet or exceed FM I-90 windstorm classification using FM approved base felt fasteners.
- E. Provide all other products required by the roof membrane system manufacturer for a complete installation of the specified system.

PART THREE - EXECUTION

3.01 General

- A. All efforts shall be coordinated to prevent moisture infiltration into the facility, the existing roof assembly, or the newly installed roofing system.

- B. Application of new materials on the roof deck, as specified in this section, constitutes acceptance of the substrate by the contractor.
- C. When using mechanical fasteners which penetrate through the structural deck, contractor shall ensure that fasteners do not penetrate conduit or miscellaneous piping located on the under side of the deck.

3.02 Surface Conditions

- A. Surfaces scheduled to receive roofing are to be free of any standing water, frost, snow or loose debris.
- B. Substrate is to be smooth, free of sharp projections, and free of obvious depressions.
- C. All metal fittings specified or shown on drawings are to be in place before roofing.
- D. All nailers shall be securely installed prior to roofing.
- E. Clean deck surfaces of all dirt, dust and other foreign matter.

3.03 Temporary Roofing Application

- 1. Adhere one ply of 300 HT without wrinkles over the entire new plywood deck surface lapping 3.5 inches on the side laps and 6 inches on the end laps, turning up adjoining walls and over roof edges as shown on the contract drawings.

3.05 Sheet Metal Flashing

- A. Metal flashing shall be formed and constructed as specified elsewhere.
- B. Metal flashing flange shall be fastened 3" on center, staggered, to the wood decking where required with approved fasteners.
- C. Adhere an 18" wide ply of ice & water shield on the edge of the flashing flange as shown on the drawings.

SECTION 07535
TEMPORARY ROOFING

- 3.06 At the end of the days work, or when precipitation is imminent, a water cut-off shall be constructed at all open edges. Cut-offs can be constructed using ice & water shield and sealant and shall be constructed to withstand protracted periods of service. Cut-offs must be completely removed prior to the resumption of roofing.
- 3.08 Clean Up
- A. Remove all debris and unnecessary roof related materials from the finished roof area.
 - B. Leave job site absolutely clean at completion of work and properly dispose of all construction debris.

-End of Section-

This Page is Intentionally Left Blank

PART ONE - GENERAL

1.1 Description

- A. Work Included: Provide all new sheet-metal work in connection with roofing work and parapets such as drip edges, counter flashing, gravel stops gutters, and step flashings.
- B. Related Work Described Elsewhere
 - 1. Roofing
 - 2. Sealant and Caulking

1.2 Quality Assurance

- A. Deliver only new materials to the job site. Materials to be stored in such a manner as to be protected from rain, snow, or inclement weather. When storing materials on the roof, do not overstress the deck.
- B. In the event of damage, immediately make all repairs and replacements to the approval of the consultant and at no additional cost to the owner.

1.3 Guarantee

- A. All new materials and workmanship covering work provided under this section of the specifications shall be guaranteed in writing by the contractor to maintain all sheet metal flashing in a watertight condition without cost to the owner for a period of two (2) years after date of final payment.

PART TWO - PRODUCTS

2.1 Design

- A. In addition to complying with all pertinent codes and regulations, comply with pertinent recommendations contained in "Architectural Sheet Metal Manual", current edition, as published by SMACNA.
- B. Sheet metal shall be formed sheet shapes as indicated on the drawings and in conformance with details on the approved shop drawings.
- C. Where sheet metal is required and no material or gauge is indicated on the drawings, provide the highest quality and gauge commensurate with the referenced manual.

SECTION 07620
RELATED SHEET METAL

- D. Counter flashing, drip edges, expansion joints, and gravel stops shall be the gauge and thickness recommended by the SMACNA Manual. In no case, however, shall any material be less than the following:
1. Stainless Steel (AISI Type 304, ASTM A-167 Finish) - 26 Gauge
 2. Lead (Common Desilverized Pig Lead) - 4 lbs/sq. ft.
 3. Pre-finished aluminum with a twenty year warranty on the polymer finish - 24 Gauge
 4. G-90 Galvanized steel - 24 Gauge
- E. Counter flashing shall be furnished where indicated on drawings at the top edge of all base flashing. Form flashing in not more than 10' lengths, lap ends 3", and caulk all loose lock joints (watertight). Counter flashing shall overlap base flashing a minimum of 3".
- F. Dissimilar metals shall not be allowed to come into contact with one another. Provide bituminous paint or other protective coating on concealed surfaces to prevent interaction of materials.
- G. Provide hot dipped zinc coated fasteners for exterior use. Select fasteners for the type, grade, and class required. Use only 304 series stainless-steel fasteners with stainless-steel sheet metal unless specifically shown otherwise on the detail drawings.
- H. Unless specifically shown otherwise on the detailed drawings, all exposed fasteners have EPDM faced stainless steel washers.
- I. Solder shall be 50-50 tin/copper in accordance with ASTM B-32.
- J. Furnish formed sheet metal for installation under this Section as shown in the Drawings and/or Specifications.
- K. New gutters shall be formed from aluminum sheet, 0.050 inches thick. Match profile of drawings, complete with end pieces, outlet tubes, and other special pieces as required. Fabricate in minimum 96-inch long sections of size indicated but no less than according to SMACHA's "Architectural Sheet Metal Manual." Provide wire strainers of compatible metal at outlet.

PART THREE - EXECUTION

3.1 Inspection

SECTION 07620
RELATED SHEET METAL

- A. Examine the areas and conditions under which work of this section will be installed. Correct conditions detrimental to the proper and timely completion of the work. Do not proceed until unsatisfactory conditions have been corrected.

3.2 Workmanship

- A. Form all sheet metal accurately and to the required dimensions and shapes.
- B. All exposed edges of cut sheet metal shall be folded back on concealed surfaces.
- C. Form, fabricate, and install all sheet metal so as to adequately provide for expansion and contraction in the finished work.
- D. Whenever possible, secure metal by means of clips or cleats without fastening through exposed metal.

3.3 Weatherproofing

- A. Finish all sheet metal watertight and weather tight where so required.
- B. Where lap seams do not have a joint cover, lap according to pitch, but in no case less than 3".
- C. Make all lap seams in the direction of the water flow.

3.4 Joints

- A. Join parts with rivets or sheet-metal screws where necessary for strength or stiffness. All joints shall be soldered; or in the case of aluminum, welded, unless shown otherwise on the detailed drawings.
- B. Provide suitable watertight expansion joints for all sheet metal as required for proper installation.
- C. Caulking of sheet metal shall be neatly and thoroughly performed for a watertight seal.
- D. Join gutter sections with riveted and welded joints. Apply 12" strip of fully adhered 45 mil thick reinforced EPDM liners on top of the gutter joints. Ensure that the EPDM material used is compactable with WP-300HT as specified.

3.5 Fastening

- A. Secure metal as per detailed drawings.

SECTION 07620
RELATED SHEET METAL

- B. All clips and cleats are to be fastened a maximum of 12" on center with self-tapping screws or 6" on center with barbed roofing nails.
- C. On the roof side, copings are to be fastened a maximum of 24" on center with washers and screws through slotted holes.
- D. For concealed fastening into wood, use hot dipped, double coated zinc ring shank roofing nails 1 3/4" X 11 gauge.
- E. For exposed fastening into concrete, use masonry/concrete anchors with EPDM faced stainless steel washers.
- F. For exposed fastening into wood, use screws with EPDM faced stainless steel washers.
- G. All fasteners to be corrosion resistant coated.

3.7 Protection

- A. Roof surfaces shall be adequately protected to prevent damage. Keep all scrap metal off of roof surface at all times.

3.8 Soldering

- A. General: Thoroughly clean and tin all joint materials prior to soldering.
- B. Use of heavy soldering copper of a blunt design, properly tinned for use.
- C. Perform all soldering slowly with well heated soldering copper in order to heat seams thoroughly and to completely fill them in.
- D. Make all exposed soldering of finished surfaces neat, full flowing and smooth
- E. After soldering, thoroughly wash and flux with a soda solution

3.9 Protection

- A. Roof surfaces shall be adequately protected to prevent damage. Keep all scrap metal off of roof surface at all times.

3.10 Clean-Up

- A. Debris from sheet-metal work shall be frequently removed from building site as it accumulates.

SECTION 07620
RELATED SHEET METAL

- B. Leave job site absolutely clean at completion of work and properly dispose of all construction debris.

- END OF SECTION -

This Page is Intentionally Left Blank

PART ONE - GENERAL

1.1 Description

- A. Work Included: Throughout the work, caulk and seal all joints where shown on the drawings and elsewhere as required by the Specifications to provide a positive barrier against passage of air and passage of moisture.
- B. Related Work Described Elsewhere
 - 1. Adhere strictly to the caulking and sealant specifications and to the detail drawings.

1.2 Quality Assurance

- A. Qualifications of Manufacturer: Products used in this work shall be produced by manufacturers regularly engaged in the manufacture of similar items and with a history of successful production acceptable to the Owners Representative.
- B. In acceptance or rejection of the work of this section, there will be no allowance for lack of skill on the part of the workmen.
- C. Sealant to conform to ASTM C920.

1.3 Product Handling

- A. Deliver materials to the job site in original, unopened containers. Materials are to be stored in a protected area between 40°F to 80°F.
- B. Do not retain on the job site any material which has exceeded the shelf life recommended by its manufacturer.
- C. Protect all surfaces from staining or damage. All damaged work shall be repaired or replaced as directed by the consultant and at no additional cost to the owner.

1.4 Job Conditions

- A. Do not apply caulking or sealant when the surface temperature is below 40°F or above 125°F. Do not apply materials when surface is damp or during cold, rainy, or frosty weather.

1.5 Submittals

- A. Color chart for each sealant will be delivered to the Owners Representative. Colors for each sealant will be selected from the manufacturers standard colors by the Owners Representative.

1.6 Warranty

- A. Furnish a written guarantee signed by the application contractor or firm, warranting the materials and workmanship to be watertight for a period of two years from date of completion of the work.

PART TWO - PRODUCTS

2.1 Sealant

- A. General: Except as specifically otherwise directed by the Owners Representative. Use only the type of sealant described in this section.
- B. Sealant shall be one of the following:
 - 1. "Sika-Flex-1A", manufactured by Sika Corporation, Lyndhurst, New Jersey, 07071.
 - 2. "Sonolastic NP-1", manufactured by Sonneborn, 7711 Computer Avenue, Minneapolis, Minnesota, 55435.
 - 3. "Dymeric", manufactured by Tremco, Cleveland, Ohio.
 - 4. "Chem Calk 900", manufactured by Bostick Division of the Emhart Chemical Group, Huntingdon, Pennsylvania.

2.2 Back-up Materials

- A. General: Use only those back-up materials which are specifically recommended for this installation by the manufacturer of the sealant used, and which are non-absorbent and non-staining. Back-up materials must be 1-1/2 times the width of the joint.
- B. Acceptable Types Include:
 - 1. Closed-Cell, Resilient Urethane or Polyvinylchloride Foam.
 - 2. Closed-Cell, Polyethylene Foam.
 - 3. Closed-Cell sponge of vinyl or rubber.

- 2.3 Cleaner: Xylol, toluene, or commercial solvent recommended by the sealant manufacturer.
- 2.4 Primer: Shall be as recommended by sealant manufacturer, if required.
- 2.5 Other Materials

All other materials not specifically described but required for complete and proper caulking and installation of sealant shall be first quality of their respective kinds, new, and as selected by the contractor subject to the approval of the owner.

PART THREE - EXECUTION

- 3.1 Examine the areas and conditions under which work of this section will be performed. Correct conditions detrimental to the proper and timely completion of the work. Do not proceed until unsatisfactory conditions have been corrected.
- 3.2 Preparation
 - A. Concrete and Ceramic Tile Surfaces
 - 1. All surfaces in contact with the sealant shall be dry, sound, and well brushed and wiped free from dust.
 - 2. Use solvent to remove oil and grease, wiping the surfaces with clean rags.
 - 3. Remove all bitumen from joint area.
 - 4. Where surfaces have been treated, remove the surface treatment by use of sandblasting or wire brushing.
 - 5. Where back-up material is required, inset the approved backer rod or bond-breaker tape in the joint cavity to the depth required.
 - B. Steel Surfaces
 - 1. Use solvent to remove oil and grease, wiping the surfaces with clean rags.
 - 2. Remove protective coatings on steel by sandblasting or by a solvent that leaves no residue.
- 3.3 Installation of Back-up Material

- A. Use only the back-up material recommended by the manufacturer of the sealant and approved by the owner for the particular installation, compressing the back-up material 25% to 50% to secure a positive and secure fit. When using back-up of tube or rod stock, avoid lengthwise stretching of the material. Do not twist or braid hose, or rod backup stock.

3.4 Joint Design

- A. Joint depth shall never be greater than width.
 - 1. Joint width is 1/4" to 1/2" wide, sealant depth at midpoint is to be 1/4".
 - 2. Joint width is 1/2" to 1" wide, sealant depth at midpoint is to be 3/8" to 1/2".
 - 3. Joint width is 1" to 2" wide, sealant depth at midpoint is to be 1/2".
- B. In deep joints, the sealant depth shall be controlled by the use of back-up materials to maintain the recommended depth.
- C. Where depth of joint does not permit the use of back-up material then a bond breaker strip must be installed to prevent three point bonding.

3.5 Installation of Sealant

- A. General: Prior to the start of installation in each joint, verify the joint type according to the details in the drawings and verify that the required proportion of width of joint to depth of joint has been secured.
- B. Equipment: Apply sealant under pressure with hand or power-actuated gun or other appropriate means. Guns shall have nozzle of proper size and shall provide sufficient pressure to completely fill joints as designed.
- C. Masking: Thoroughly and completely mask all joints where the appearance of sealant on adjacent surfaces would be objectionable.
- D. Installation of Sealant: Install the sealant in strict accordance with the manufacturer's recommendations as approved by the owner, thoroughly filling all joints to the recommended depth.
- E. Tooling: Tool all joints to the profile shown on the details in the drawings. Tooling to be done immediately after sealant application.

3.6 Clean-Up

SECTION 07920
SEALANT AND CAULKING

- A. Remove masking tape immediately after joints have been tooled.
- B. Keep adjacent surfaces clean and free from sealant as the installation progresses. Use solvent or cleaning agent as recommended by the sealant manufacturer.

- END OF SECTION -

This Page is Intentionally Left Blank

EXHIBIT E
WARRANTY
OF
INSTALLING CONTRACTOR

To: Central Administration
Montgomery Community College
40 West Gude Drive
Rockville, MD 20850

This warranty is for the new temporary roofing system installed on (date) _____ on the entirety of steep slope roof areas at the Science and Applied Studies Building on the Germantown Campus of Montgomery College in Germantown, MD.

The completed area of roof installation on the Sciences and Applied Studies Building totals approximately _____ square feet.

Installing Contractor

Contractor warrants to Montgomery College that, subject to the terms, conditions and limitations stated herein, Contractor will maintain or cause to be maintained, the watertight integrity of the roof repairs performed for a period of ten months, commencing with the date of completion of the repairs; that is, Contractor will make such repairs or replacements as necessary to maintain the watertight integrity of the repairs for the period of this warranty at no expense to Montgomery College.

TERMS, CONDITIONS, LIMITATIONS

Exhibit E, Contractor's Warranty
Montgomery College
Germantown Campus
Science & Applied Studies Building
October 23, 2009
Page 1 of 4

1. The term "Roofing System" as used herein shall mean the Roofing Membrane and shall include the flashing and all other work installed in conjunction with the membrane included under this two year warranty, under the terms of the agreement between Contractor and Montgomery College.
2. The owner shall notify Contractor promptly and in no event later than seventy-two (72) hours after the discovery of any leaks, punctures, ruptures in the Roofing Repairs or disrepair thereof, and shall confirm such notice in writing ten (10) days after the discovery of such condition(s).
3. This warranty shall not be applicable to any failure(s) of the watertight integrity of the Roofing System to the extent that such failures are caused by the following:
 - a) Damage to the Roofing System caused by natural disasters, including but not limited to, earthquake, lightning, hurricane, tornado, winds of gale force (except where the specifications for the installation exceed a wind uplift resistance greater than gale force), or structural failure of the building or roof deck (except that caused by Contractor), or by fire, or:
 - b) Damage to the Roofing System, after completion of installation, by any acts of negligence (other than negligent acts of Contractor), accidents or misuse, including but not limited to, vandalism, civil disobedience, acts of war, or falling objects.
 - c) Failure by the Owner to use reasonable care in making visual inspections of the Roofing System and roof drains not less than once each six (6) months, except when prevented from doing so by weather conditions or other causes out of the control of the Owner in which case such inspections shall be performed as soon thereafter as practical. Such inspections shall be made for the purpose of ascertaining if any punctures to abrasions of the Roofing Membrane or clogging of the drains have occurred, or other unusual conditions exist which could or do affect the Roofing System or Roofing Membrane.
 - d) Failure of the Owner to comply with the provisions contained in paragraphs 2 and 5 of this warranty.
4. This warranty shall be null and void if any of the following shall occur:
 - a) Any repairs or alterations are made on or through the membrane caused, authorized or permitted by the Owner of the building, or objects such as, but not limited to, fixtures, equipment or other structures are placed on or attached to the roof without

first obtaining written authorization from Contractor, subject to reasonable requirements of Contractor in making such alterations and repairs, except that the voiding of the warranty will be limited to an ascertained and described area of the Roofing Membrane or Roofing System installed, if the following conditions are fulfilled:

- 1) The area of damage or disrepair to the Roofing Membrane or Roofing System resulting from unauthorized repairs, alterations or placement of structures is confined to an area less than the whole Roofing Membrane and such area is completely ascertained by Contractor; and
 - 2) In the sole judgment of Contractor, which judgment will not be unreasonably exercised, Contractor determines that the damage or disrepair sustained will probably not affect the integrity or durability of the whole membrane or Roofing System installation; and
 - 3) The area damaged or in disrepair is repaired and restored to a warrantable condition, either by corrective work performed by Contractor, or by work authorized and accepted by Contractor. All such work, including the services of Contractor, shall be at the sole expense of the Owner; then,
 - 4) Upon the fulfillment of all of the conditions provided in 4 a), 1), 2), and 3) above, the repaired or restored area will again be included in the warranty for the remainder of the original warranty period.
- b) A significant change in the use of the building by the Owner or Owner's Lessee, thereby substantially affecting the use and the conditions for which the membrane installation was originally designed, or:
- c) Failure of the Owner to commence legal action to enforce the terms of this warranty within one (1) year from the date of expiration.
5. During the period of this warranty, Contractor and its agents and employees shall have unlimited access to the roof during regular business hours; and, in case of emergency, shall have unlimited access to the roof outside regular business hours.
 6. Contractor's failure at any time to enforce any of the terms or conditions stated herein shall not be construed to be a waiver of such terms or conditions.
 7. No other warranty, expressed or implied, is given. The Owner's sole and exclusive right and remedy and Contractor's sole obligation for any failure of the Roofing System shall be

as provided under this warranty. Contractor shall not be liable for any incidental or consequential damage to the building on which the Roofing System is installed, damage to the contents thereof, or to any other property or persons, specifically including materials and accessories below the roof deck.

- 8. This warranty shall not be transferable, except upon written acceptance of the terms of this warranty by the succeeding building Owner and inspection by Contractor of the Roof membrane prior to acceptance by Contractor of such transfer. Denial of the transfer of this warranty to a succeeding owner shall be based upon damage to the roof arising from violations of paragraphs 2, 3, and 4 hereof.

CONTRACTOR

By: _____

Title: _____

Date: _____

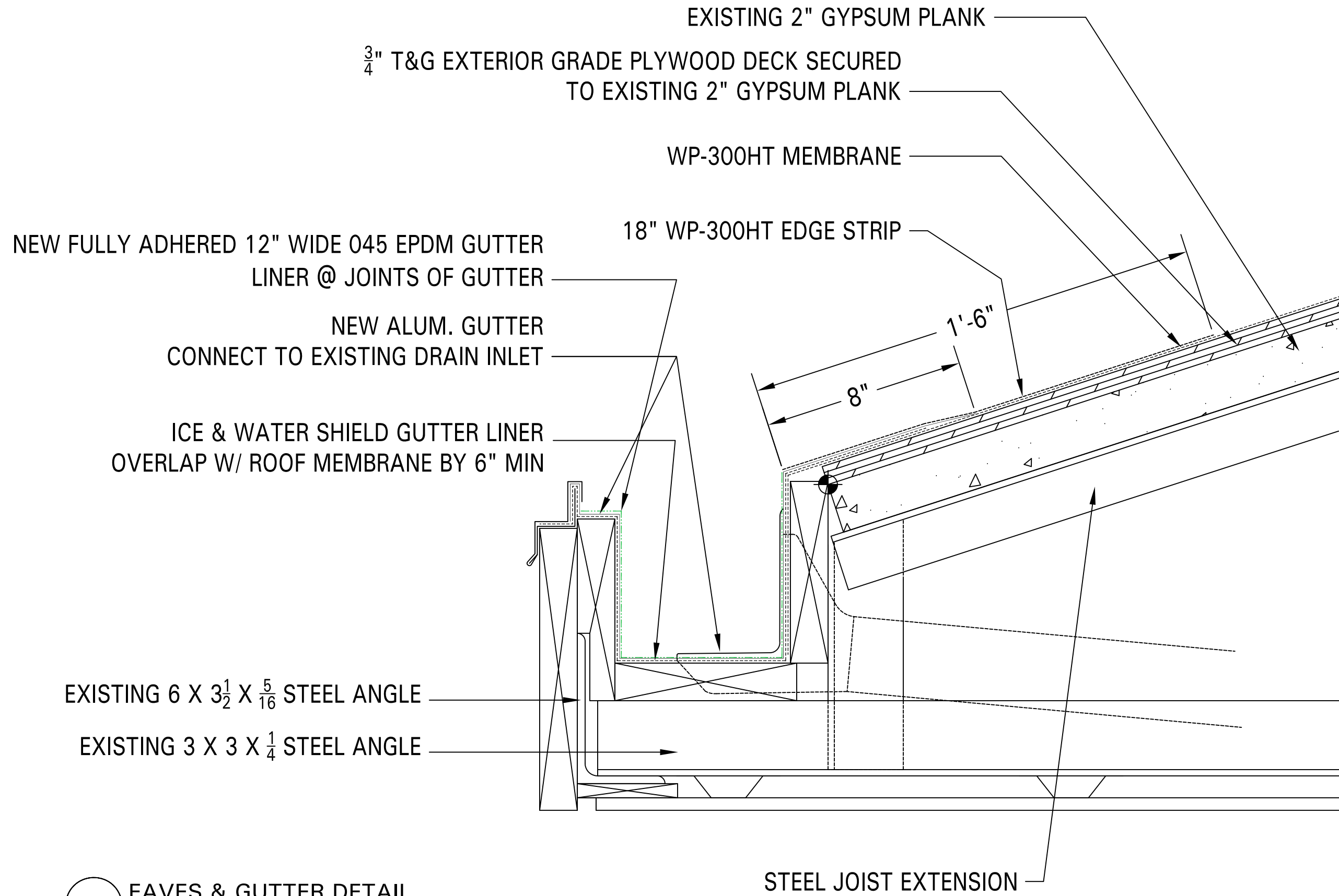

1 EAVES & GUTTER DETAIL
3" = 1'-0"

SCALE: 3" = 1'-0"	APPROVED BY: C. Harrison	DRAWN BY: BDC
DATE: 8/03/09	PROJECT NO.: 317/8712	REVISED:
PROJECT: Montgomery College		
SA Building Clay Tile Repairs		
TITLE: DETAIL	DRAWING NO.: 1	

Inspections Specifications Project Management
 Quality Control Maintenance Programs Budgeting

 530 Vaucluse Road, Stephens City, Virginia 22655
 Ph: 540/869/5276 Fax: 540/869/5276 Website: www.abs-services.com



Central Administration
 40 W. Gude Dr., Suite 200
 Rockville, Md 20850
 Telephone: (240)-567-7383

Montgomery College

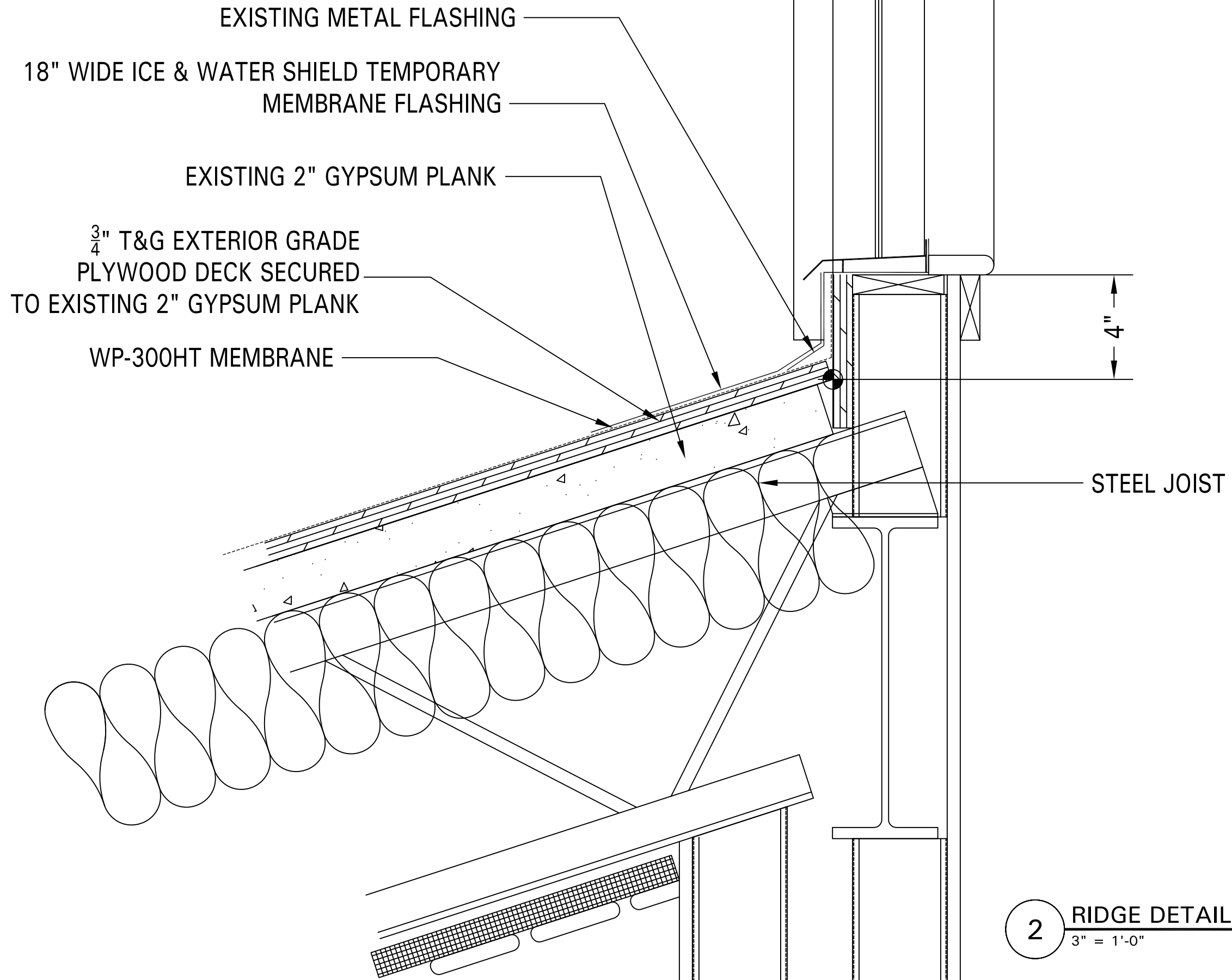
BLANK PAGE



2 RIDGE DETAIL
3" = 1'-0"

SCALE: 3" = 1'-0"	APPROVED BY: C. Harrison	DRAWN BY: BDC
DATE: 8/03/09	PROJECT NO.: 317/8712	REVISED:
PROJECT: Montgomery College SA Building Clay Tile Repairs		DRAWING NO.: 2
INSPECTIONS: Specifications, Project Management, Quality Control, Maintenance Programs, Budgeting		TITLE: DETAIL
 530 Vaucluse Road, Stephens City, Virginia 22655 Ph: 540/869/5247 Fax: 540/869/5276 Website: www.abs-services.com		
Central Administration 40 W. Gude Dr., Suite 200 Rockville, Md 20850 Telephone: (240)-567-7383		
 Montgomery College		

BLANK PAGE

18" ICE & WATER SHIELD EDGE STRIP
 3/4" T&G EXTERIOR GRADE
 PLYWOOD DECK SECURED
 TO EXISTING 2" GYPSUM PLANK
 WP-300HT MEMBRANE

NEW KYNAR
 FINISHED ALUM
 FLASHING



8"
 METAL CLEATS

EXISTING 3X12
 WOOD FASCIA

STEEL BEAM



EXISTING DRYVIT FINISH

3 RAKE EDGE DETAIL
 3" = 1'-0"

SCALE: 3" = 1'-0"	APPROVED BY: C. Harrison	DRAWN BY: BDC
DATE: 8/03/09	PROJECT NO.: 317/8712	REVISED:
PROJECT: Montgomery College		DRAWING NO.: 3
TITLE: SA Building Clay Tile Repairs		
Inspections Specifications Project Management Quality Control Maintenance Programs Budgeting		
		
530 Vaucluse Road, Stephens City, Virginia 22655 Ph: 540/869/5247 Fax: 540/869/5276 Website: www.abs-services.com		
Central Administration 40 W. Gude Dr., Suite 200 Rockville, Md 20850 Telephone: (240)-567-7383		
		

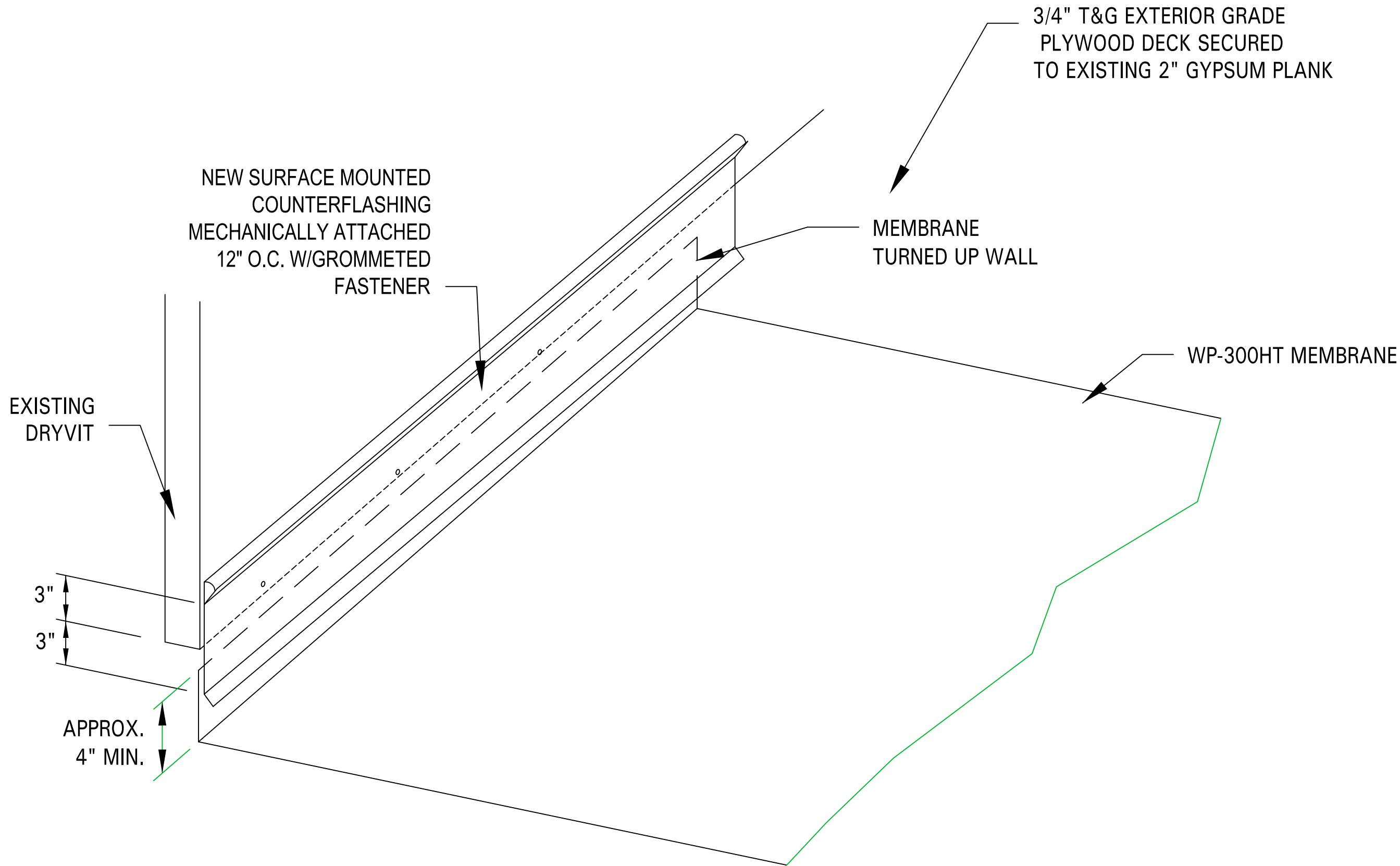
BLANK PAGE



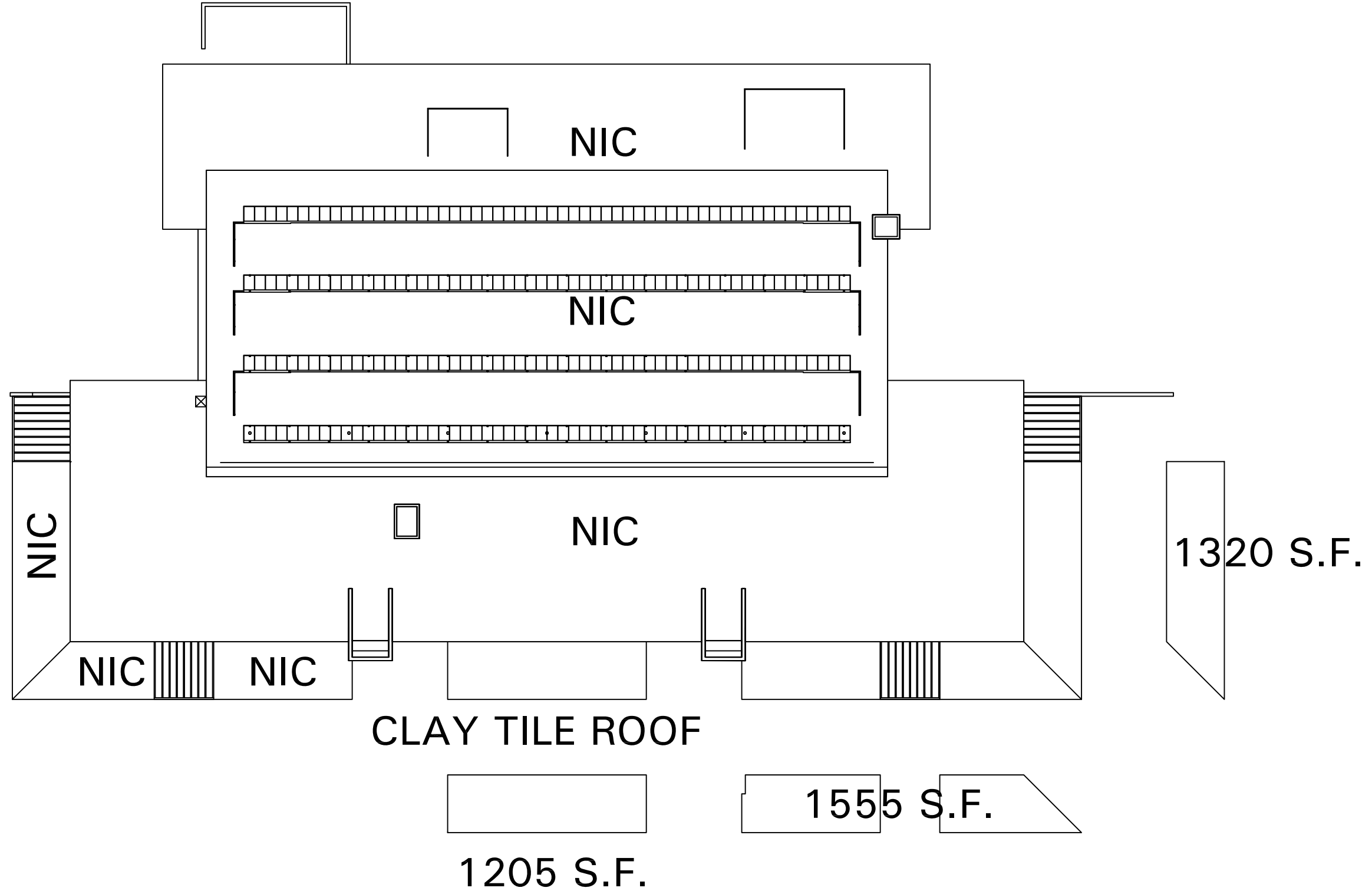

SCALE: NTS	APPROVED BY: C. Harrison	DRAWN BY: BDC
DATE: 8/03/09	PROJECT NO.: 317/8712	REVISED:
PROJECT: Montgomery College SA Building Clay Tile Repairs		DRAWING NO.: 4
TITLE: DETAIL		
Inspections Specifications Project Management Quality Control Maintenance Programs Budgeting		
		
530 Vancluse Road, Stephens City, Virginia 22655 Ph: 540/869/5247 Fax: 540/869/5276 Website: www.apu-services.com		
 Montgomery College Central Administration 40 W. Gude Dr., Suite 200 Rockville, Md 20850 Telephone: (240)-667-7383		

BLANK PAGE



SCIENCE/APPLIED STUDIES

NTS

 Montgomery College	Central Administration 40 W. Guide Drive, Suite 200 Rockville, Md 20850 Telephone: (240) 567-7983	 AEP SERVICES 530 Vaucluse Road, Stephens City, Virginia 22655 Ph: 540/869/5247 Fax: 540/869/5276 Website: www.aep-services.com	Inspections Specifications Project Management Quality Control Maintenance Programs Budgeting •	SCALE: NTS DATE: 10/23/09 PROJECT: Montgomery College - Science & Applied Studies Building PROJECT NO.: 317/4730 TITLE: ROOF PLAN	APPROVED BY: C. Harrison PROJECT NO.: 317/4730 DRAWING NO.: RP-1
	DRAWN BY: A. Levy REVISED:				

BLANK PAGE